



SMART.  
SUSTAINABLE.  
ENERGY-EFFICIENT.  
HEALTH-  
PROMOTING.

*Luxury*



We are so convinced of the  
quality of our hot tubs in the  
XE models, that we have

**Warranty  
&  
Guarantee**

for the first 2 years as a manufacturer  
with the end customers ourselves

XE

The new generation of XE models. The original.  
With the unique Various Hydrojets

[www.whirlcare.com](http://www.whirlcare.com)

Welcome to the Länd

## Whirlcare® at the gateway to the Black Forest

On the edge of the idyllic village of Deißlingen-Lauffen, directly on the B27 between Rottweil and Villingen-Schwenningen - at the gateway to the Black Forest - our whirlpool and swim spa production facility is located on an area of over 62,000m<sup>2</sup>. Here, energy, digitalization, innovation, industry standard 4.0 and, above all, sustainability - in production and in our products - are our top priorities. With an additional outdoor exhibition of approx. 1,500m<sup>2</sup> and a separate showroom of over 5,000m<sup>2</sup>, the manufactured whirlpools and swim spas are not only built here, but also exhibited for testing and trial whirls.





Welcome to the world of top hot tubs from Whirlcare®. Our XE models have earned the reputation of being the best hot tubs in the world - and not only our satisfied customers claim this, but also renowned hot tub specialist dealers. However, we do not make this claim ourselves, but boldly face up to the global competition. We focus on transparency and are ready for any challenge.

Otmar Knoll, Director und Founder  
Whirlcare® Industries GmbH



### Large area, short distances

The Spas United Group GmbH combines the Whirlcare® Industries production facility with the WCI-Tec research and development department and Europe's largest wellness exhibition, Whirlpools World One, under one roof.



*Freedom*  
is the foundation  
for true luxury at home

„I'm surrounded by luxury,  
I can do without the necessities!"  
(Oscar Wilde)

# Whirlcare® Industries GmbH

Luxus & Wellness redefined

SMART  
SUSTAINABLE  
ENERGY-EFFICIENT  
HEALTH-PROMOTING

Experience the extraordinary world of health whirlpools from Whirlcare®, where the highest demands are placed on quality and your health. Unlike conventional relaxation and fun whirlpools, we rely on the healing powers of hydrotherapy to promote your physical and mental health. Hydrotherapy is a proven natural healing technique that specifically targets joint and muscle pain, relaxes your muscles, boosts circulation and the immune system, stimulates blood flow, reduces stress and even lowers blood pressure. These beneficial health effects have been proven by numerous scientific studies. At Whirlcare®, we attach great importance to combining health and wellness. Our whirlpools have been specially developed to offer you the best conditions for your personal health promotion. By combining different types of massage, individually adjustable water pressure and a pleasant water temperature, we create an optimal environment for your hydrotherapy. The German Society for Preventive Health Care (DGGV) also recommends the use of whirlpools to promote health and prevent illness. Trust in the power of water, which is regarded as healing and valuable in many cultures. In addition to the health aspects, you should of course not forget the relaxing and entertaining element of Whirlcare®. Our whirlpools offer you the perfect combination of health promotion and pure fun. Enjoy moments of relaxation, leave the stress of everyday life behind you and immerse yourself in a world of well-being and pleasure. Discover the unique combination of health, relaxation and fun at Whirlcare®. Immerse yourself in the world of hydrotherapy and experience how our whirlpools can improve your quality of life.

You can rely on our years of experience, high-quality materials and first-class workmanship - for a whirlpool experience that will delight you. Time for a whirlpool session in the wonderfully positioned Whirlcare® model of the new XE generation - Manufactured, Designed and Made in Germany. Welcome to Whirlcare Industries GmbH. The world's first manufacturer in the industry with climate-neutral production. Almost 100% of the materials used are recyclable or already made from recycled materials. A company with a sustainability strategy for the future, so that you can enjoy the real wellness experience with a clear conscience.

## Prerequisite for the best hot tubs in the world

### PHILOSOPHIE

Whirlcare® hot tubs and swim spas combine technology, health and ecology with wellness and luxury. And all of this with sustainability, environmental protection and CO<sub>2</sub> savings in mind. Whirlcare® Industries is a pioneer of the new generation of hot tubs and swim spas with its future-oriented manufacturing process. Designed, engineered and manufactured in Germany according to the strictest quality criteria. Our own research and development department stands for the company's trend-setting innovative strength. We help successful people to reduce stress, relieve tension and increase performance.



Company of the year Award 2022 & 2023

# The Whirlcare® table of contents

Or why we build the best hot tubs in the world

## ABSOLUTE TRANSPARENCY

### Health & Well-being

from page 8

Luxury and Wellness redefined

What can Whirlcare® hot tubs do for your health?

- Page 10 Die 3 Whirlcare® Essentials    The warm water  
The buoyancy in the water  
The underwater massage
- Page 12 Die 5 Whirlcare® Senses    Color-light  
Sound  
Taste  
Aroma
- Page 16 SKINOXYFORM®
- Page 18 Relief & Ergonomics
- Page 20 The hydromassage
- Page 21 The massage zones
- Page 22 The 9 Whirlcare® Benefits for health & well-being



### Smart & energy-efficient / Performance

from page 24

Let's take the  
Whirlcare® hot tub apart

- Page 26 Various Hydrojets
- Page 30 HydroPowerPump
- Page 34 Smart-Spa-Control
- Page 38 HeatEnergyPump (heat pump)
- Page 40 UVZONATOR
- Page 41 Whirlclear - pure water (water filter)
- Page 42 Insulation
- Page 43 Climate-chamber Test
- Page 44 Protective Panel
- Page 45 Protective Coat
- Page 47 Whirlcare® XE-Technology at a glance
- Page 48 The Whirlcare® warranty periods



### Construction & Equipment / Durability

from page 49

- Page 50 Tub base & Steelframe
- Page 51 Tub body
- Page 52 Tub reinforcing
- Page 54 DESIGN
- Page 55 Die 7 Whirlcare® Aesthetics
- Page 56 3 equipment variants (Premium, First Class, Luxury)
- Page 57 Soundsystem, Aromakur-Injector, hot tub lightning
- Page 58 Skinoxyform®
- Page 59 Airblower with heater
- Page 60 Extended comfort highlights

Vulcano jet  
Waterfall  
Head-/neck cushion  
Control panel  
Diverter  
Cupholder  
Handle  
Water drain valve



## The new generation

[www.whirlcare.com](http://www.whirlcare.com)

## The whirlcare® hot tubs & swim-spas

from page 62

Equipment variants

Premium, First Class & Luxury

- Page 65 Master XE Premium, First Class & Luxury
- Page 67 Attraction XE Premium, First Class & Luxury
- Page 69 Perfection XE Premium, First Class & Luxury
- Page 71 Excellence XE Premium, First Class & Luxury
- Page 73 Magic XE Premium, First Class & Luxury
- Page 75 Teamplayer XE Premium, First Class & Luxury
- Page 77 Release XE-S Premium, First Class & Luxury
- Page 79 Artwork XE-S Premium, First Class & Luxury
- Page 81 Impression XE-S Premium, First Class & Luxury
- Page 83 Identity XE-S Premium, First Class & Luxury
- Page 87 Swim-Spa Surfer Premium & First Class
- Page 89 Swim-Spa Wellpower Premium, First Class & Luxury
- Page 91 Swim-Spa Family Premium, First Class & Luxury



## Further facts & features

from page 92

that most manufacturers do not talk about

- Page 94 Deliberately no water fountain / Artificial intelligence
- Page 95 Water characteristic curve / Variable ABS supports
- Page 97 Smart technology

## Sustainability

from page 98

Home. Energy. Future.

Taking responsibilities

- Page 100 Whirlcare® production facility
- Page 103 Hot tub added value
- Page 104 Sustainability strategy
- Page 105 The environmental factor
- Page 107 The energy factor
- Page 108 Award-winning brand & products
- Page 109 List of sources
- Page 111 Imprint



SMART  
SUSTAINABLE  
ENERGY-EFFICIENT  
HEALTH-PROMOTING





Health  
is the first duty in life



## HealthNo promises without facts

Our health tips are guideposts and are verified by independent doctors.

However, treatments with hot or cold water have been around for much longer. People have been bathing in hot springs for thousands of years to relieve pain and improve their well-being. Even the ancient Greeks attributed a special healing power to the water, and traces of Roman bathing culture can still be found everywhere today. The honorary Roman citizen Antonius Musa is regarded as the real father of hydrotherapy: in 23 BC, he cured Emperor Augustus of a serious illness with water treatments. Water is therefore not only the source of all life, but also a natural remedy<sup>1</sup> whose positive properties are utilized in hydrotherapy. It is a natural healing method that aims to alleviate joint and muscle pain<sup>9</sup>, relax the muscles, strengthen the circulation and immune system, stimulate blood flow, reduce stress and even lower blood pressure<sup>2</sup>.

But what happens to our body in water? According to Archimedes' principle, the buoyant force of a body is equal to the weight of the displaced medium, in this case water. As a result, the body in the water only has about ten percent of its actual weight. For comparison: on the moon you "weigh" considerably more - here it is around 30 percent of your body weight! The natural buoyancy of the water creates a feeling of (almost) weightlessness. This can help to reduce tension and relieve pressure on joints, ligaments and bones. Added to this is the hydrostatic pressure from the surrounding water, which has a positive effect on the blood vessels: the circulation is stimulated and the oxygen supply to the blood is improved<sup>3,4</sup>.



Dr. med. Bertram Schädle

**Specialist in anesthesia,  
intensive care and preclinical  
emergency medicine.**

# 3 Die 3 Whirlcare®

## Essentials

What can the Whirlcare® hot tub do for you?



### The warm water

Water temperatures of 36-40°C relax the muscles and relieve tension throughout the body, especially in the back and legs. Often, stress, exertion and intense tension cause the vascular walls in the body to harden. A hot tub bath relieves this by allowing the warm water to dilate the blood vessels and regulate blood pressure. For better blood flow to the internal organs. The flowing feel-good effect in the body rests our soul and regenerates not only the body, but above all the psyche.

### Buoyancy in the water

The body only has around ten percent of its actual weight in the water. The natural buoyancy of the water in the hot tub creates a floating feeling of (almost) weightlessness. Water presses evenly on the body from the outside. As a result, the water pressure prevents sagging. This can increasingly help to reduce tension and relieve joints, ligaments and bones. In addition, the hydrostatic pressure has a positive effect on the blood vessels: the circulation is sustainably stimulated and the oxygen supply to the blood is improved.



### The underwater massage

Provided they are correctly placed and strong enough, the different massage jets are a truly relaxing and health-promoting element. At different levels, it is possible to loosen the muscles as well as adjacent joints and ligaments. Minor injuries can heal more quickly. Tissue is loosened and regional blood circulation is improved. An individual hydromassage is the ideal support & prevention of muscle cramps, relief of cramps and joint pain. It boosts the metabolism, supports the circulation and improves the quality of sleep.

For optimum effect, the water temperature should be approx. 1°C higher than body temperature, depending on how you feel

# The factor HEALTH



## The warm water helps with

Tension. Perfect for sore muscles  
 POSITIVE PSYCHOLOGICAL EFFECT  
 Better blood flow to the internal organs  
 Regulation of blood pressure

## The buoyancy in the water ensures

An (almost) weightlessness  
 Joint, ligament and bone protection\*  
 To stimulate the circulation  
 For an improved oxygen supply to the blood

## The underwater massage

Loosens muscles, tissue, neighboring joints  
 and ligaments  
 Relieves cramps and joint pain  
 Promotes the metabolism  
 Supports the circulation  
 Improves the quality of sleep



# 5 Whirlcare®

## Senses

The Whirlcare® sensory therapies and their effect

## COLORED LIGHT THERAPY



Eye. Visual perception Colored light not only looks beautiful, but also subconsciously influences the psyche. Color light therapy is based on the assumption that each color has its own wave spectrum and therefore a certain effect: stimulating or calming, exhilarating or balancing. In alternative medicine, color light therapy is used to alleviate psychological and, above all, psychosomatic complaints. However, it is also used to specifically stimulate or harmonize bodily functions and to eliminate disturbances in energy flow. Whirlcare® whirlpools with color light therapy have various LED light points that can be located above or below the waterline.

Red is a strong color that has a stimulating to arousing effect and can also be aggressive in excessive doses. Of course, red also stands for love and therefore also for passion, warmth and sexuality. In color therapy, red is used to combat tiredness and increase activity. Red has a stimulating effect on circulation and metabolism.

Blue is associated with the sky and water. It has a calming and cooling effect. The color blue can help us escape from everyday life and satisfy our longing for peace and quiet. It is also said to relieve muscle tension and migraines.

Green symbolizes balance and harmony. Green is said to have a calming, nerve-strengthening and inspiring effect and can therefore be used for headaches, inflammation, nervousness or sleep disorders, for example.

Yellow is a bright color that is perceived as uplifting, vitalizing and liberating. It is said to support the ability to think, help with gastrointestinal disorders and strengthen the nervous system.

White is not actually a color, but the sum of all the colors of light. However, it plays a major role in color light therapy. White symbolizes purity, clarity and goodness. This is why white clothing is often worn during meditation, as white can be helpful for inner cleansing.

Orange stands for joy, activity and an affirmation of life and is considered a source of strength in cases of physical or mental exhaustion. The color not only has a stimulating effect on the psyche but, according to color therapy, also on the metabolism, immune system and cell tissue.

Violet is used against despair and hopelessness as well as for cleansing and purification. Violet is considered a healing color of the spirit, has a strong meditative effect and is said to promote mental balance.



Eye. Visual perception

## SOUND THERAPY

It can spur us on to peak performance, make us melancholy, make us happy and help us relax: Music. It gives us goosebumps in films, motivates us during sport, and if you want to switch off after a stressful day, close your eyes and listen to your favorite songs - balm for the ears, mind and soul. The fact that music affects us so intensely is due to its effect on the areas of the brain that are responsible for emotions. Rhythmically emphasized pieces tend to be stimulating and invigorating, while gentle melodies calm and relax. However, music not only influences our mood, but also our physical condition: Heart rate and pulse rate, blood pressure and breathing rhythm can all change positively.

Ear. Auditory perception



„Music is light for the soul,  
a hymn to life!“  
(Else Pannek)

## TASTE THERAPY

Naturally on your own responsibility via cup holder

Our stimulants. A cocktail, a cold beer, an Aperol Sprizz or the famous glass of wine, which has a positive effect on the composition of blood lipids and helps to reduce harmful LDL cholesterol. Only in moderation, of course. The blood flow and coagulation properties of the blood also improve. This also reduces the risk of thrombosis. The favorite drink in the Whirlcare® feel-good whirlpool therefore has a double and triple effect, freeing body and mind. Illuminated cup holders help you to place your drink comfortably and safely. Thanks to the indirect light, the cup holder is also an eye-catcher and visual highlight in the whirlpool. With your favorite drink, nothing stands in the way of your own "taste therapy".



Mouth. Gustatory perception

"It is absolutely possible that beyond  
the perception of our senses  
unimagined worlds are hidden!"

(Albert Einstein)



# AROMA THERAPY

Smells evoke memories and trigger emotions. This happens because they have a direct effect on the limbic system in the brain, which is responsible for emotions. In aromatherapy, a branch of phytotherapy (herbal medicine), we make use of this: Stimulating fragrances stimulate the body, mind and soul and can influence the state of mind or physical condition. Knowledge of the power of essential oils is ancient:

Even the ancient Egyptians used plant essences for embalming, cosmetics, massage and health. The close connection between scents and emotions has also been reflected in numerous idioms, for example when someone has "a fine nose" or "the right smell". Aromatherapy is regarded as a beneficial, holistic complementary therapy. The appropriate fragrances are sprayed into the Whirlcare® water and used, which can have a particularly positive effect on mental and emotional disharmony. Only special fragrances suitable for whirlpools may be used, as otherwise the water quality, the hydrojets and the pipe system may be damaged. The effect should range from calming and antispasmodic to mood-enhancing, concentration-enhancing and pain-relieving. Depending on your mood and emotional state, you can improve your well-being by choosing the right aroma fragrance.



Nose. Olfactory perception

## Scent experience

Whirlcare® AROMAKUR - your whirlpool fragrances for pure relaxation. Experience moments of serenity and well-being. Our fragrance essences in combination with the gentle bubbling of your whirlpool give you balance and relaxation. Forget the hustle and bustle of everyday life and use the scents of nature for your own personal wellness oasis.

- Contains 100% natural essential oils
- Long-tasting and pleasant fragrance
- No foaming or cloudiness in the pool
- Sustainable production made in Germany
- Vegan and without artificial additives



### **CITRONGE** (Lemon & Orange)

The combination of lemon and orange invites you to enjoy a good mood, balance and joie de vivre. The fruity, tangy notes are designed to help give you a boost of freshness after a tiring day. Tired spirits are revived.



### **GINGERETTE** (Ginger & Lime)

Ginger has always been known for its helpful properties and, in combination with lime, the aroma with its sweet note can provide invigoration and refreshment. Let the fragrance work its magic on you and enjoy the pleasant freshness of ginger and lime.



### **LACALYPT** (Mountain Pine & Eucalyptus)

With its fresh, mild and woody fragrance, Lacalypt stands for strength and mobility. The combination of mountain pine and eucalyptus scents invites you to take a walk in the woods while you indulge yourself in the whirlpool bath.



### **LAROSE** (Lavender & Rose)

With its initially dominant lavender note, LAROSE adds a touch of Mediterranean flair to your wellness treatment. The combination with the scent of fresh rose petals helps to symbolize contact with nature. Larose can help you find time to breathe deeply and reduce stress.



# AROMAKUR

Exclusively available from Whirlcare®  
**The finest Four Collection**  
The soothing aroma treatment fragrances for use in spas,  
hot tubs and bubble baths



# SKINOXYFORM®

## The H<sub>2</sub>O-O<sub>2</sub> -Fountain of youth

Health-promoting water-oxygen therapy for the skin

Looking young has nothing to do with age. Skinoxyform® renews your skin and protects our largest organ against external influences such as air pollution, pathogens, heat and cold. However, the skin is also a reflection of our soul: stress, smoking, environmental toxins and an unhealthy lifestyle leave their mark. The skin looks tired, sallow and sagging. Oxygen therapy helps your skin to store nutrients, absorb medication and eliminate toxins and metabolic products. Millions of tiny oxygen bubbles caress your body while you lie relaxed in the Whirlcare®. The micro-bubbles penetrate deep into the skin, removing impurities and providing it with natural moisture. The production of collagen, responsible for strength, structure and firmness, is stimulated. You feel refreshed and balanced. Skinoxyform®, the innovative hydrooxygen application from Whirlcare®, increases the oxygen content in the water by more than 70 percent. This can stimulate the metabolism, improve cell growth and deep hydration of the skin, and even reduce lines and wrinkles. The microscopic oxygen particles, which give the whirlpool water a milky white appearance, are produced by a special pump and injected into the water.

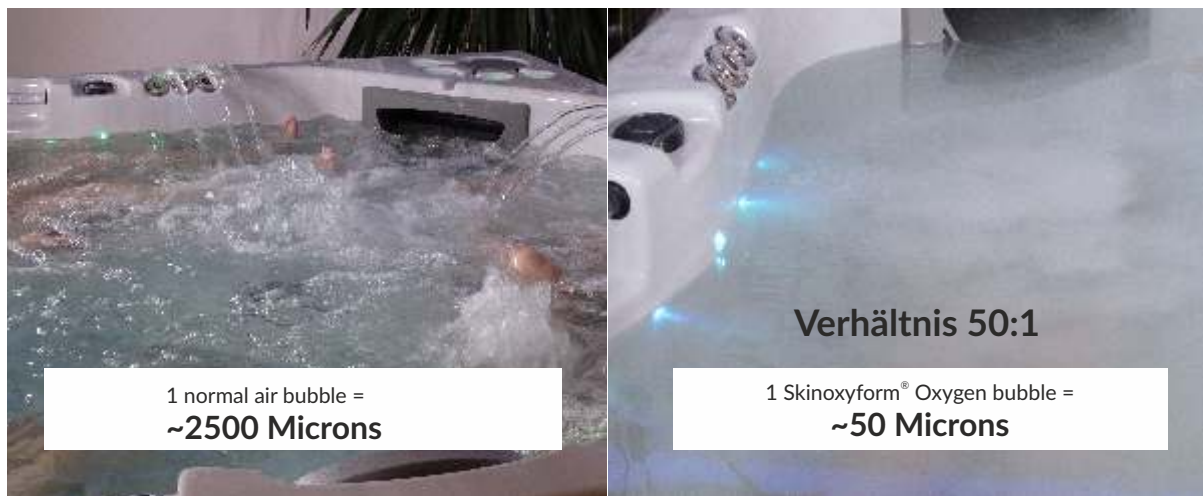

### For comparison:

A classic air bubble produced by an airjet is around 50 to 100 times larger. Thanks to their small size, the Skinoxyform bubbles do not burst in the water but on the surface and keep the heat evenly distributed in the Whirlcare® hot tub. This so-called "sauna effect" is known to help strengthen the heart and circulation. In addition, our Skinoxyform® application can neutralize free radicals responsible for skin aging and increase serotonin levels, which affect sleep quality.







Breathing in the negative ions can lead to deeper relaxation and increased serotonin levels. Serotonin controls many different processes. In the central nervous system, for example, serotonin is an important messenger substance that influences important processes such as body temperature, appetite, pain assessment, mood and drive. It even includes emotions and feelings, the central reward system and the all-important sleep-wake cycle. Serotonin puts you in a good mood, gives you restful sleep and increases your drive. It not only affects the psyche, but also regulates body temperature and aids digestion. As a neurotransmitter, it transmits stimuli that cause the heart to beat, muscles to move and thought processes to take place.

## INCREDIBLY GOOD EFFECT

- Skinoxyform® enables natural deep cleansing & hydration
- Sauna effect provides even heat and can boost circulation
- Provides oxygen for better skin metabolism
- Can have a positive effect on crow's feet and fine lines and wrinkles
- Promotes skin cell growth, can reduce scars and skin blemishes
- Can alleviate the symptoms of eczema
- Free radicals that lead to skin ageing can be neutralized

### A true fountain of youth for body & soul

The tiny design of the microbubble facilitates deep penetration into the skin. The skin's collagen production is stimulated. An important factor for a wrinkle-free appearance. Collagen is the most common protein in the human body. The protein for smooth skin. Only a strong collagen framework can keep our skin wrinkle-free for longer. It does not work to simply apply collagen to the skin. For a long-term effect, the body's own collagen production must be stimulated. This is where we are essential. Immerse yourself in a new, younger, more vital YOU. Completely without any invasive cosmetic surgery. Absolutely organic.



Skin. Haptic perception

## Relief

### The backbone of our body

80 percent of Germans suffer from back problems at least once in their lives. They are the number one widespread ailment and the most common reason for sick days. "The main triggers for muscle hardening are incorrect posture, one-sided strain, lack of exercise or constant stress; in addition to stretching exercises, heat and massages can also provide relief - applications that are optimally combined with hydromassage in a Whirlcare®," says Dr. Bertram Schädle. For thousands of years, people have bathed in hot springs to relieve their pain or increase their well-being. The brochure "Naturheilverfahren - Sichere und wirksame Methoden der naturheilkundlichen Medizin" (Safe and effective methods of naturopathic medicine) lists the acute effects of the heat stimuli from hydrotherapy as including circulation stimulation, reflector muscle relaxation and numerous options for pain therapy (publisher: Europäisches Gesundheitszentrum für Naturheilverfahren - Sebastian Kneipp Institut GmbH) Dr. Schädle points out that the hydro massage in a Whirlcare® specifically promotes blood circulation. This can help to relieve tension and alleviate pain. At the same time, the heat from the water is transferred to the surface of the skin through direct heat conduction, creating a feeling of well-being. In addition, the buoyancy of the water relieves joints, ligaments and tendons and creates a feeling of (almost) weightlessness: you have the feeling of floating. "Provided they are positioned correctly and the strength is adjusted, the massage jets in a whirlpool are a relaxing and soothing element. In Whirlcare® whirlpools and swim spas, explicit attention is paid to ensuring that the hydrotherapy jets work directly on the muscular problem zones and reaction points," confirms the expert. Unfortunately, this is not the case with all whirlpool manufacturers. Schädle admits bear in mind that incorrectly positioned jets can even be harmful under certain circumstances. In particular, he warns against massage jets that are aimed directly at the spine, i.e. placed in the middle of the back area of a lounge or seat in the hot tub.

## Ergonomics

The ergonomics and body-friendly consideration of the anatomy of the user of a hot tub, e.g. body size and body volume as well as anatomy, is very important. Design, ergonomics, technology, comfort, health and sustainability are also of particular importance. Unfortunately, there are still many manufacturers who do not take this very important health aspect into account.

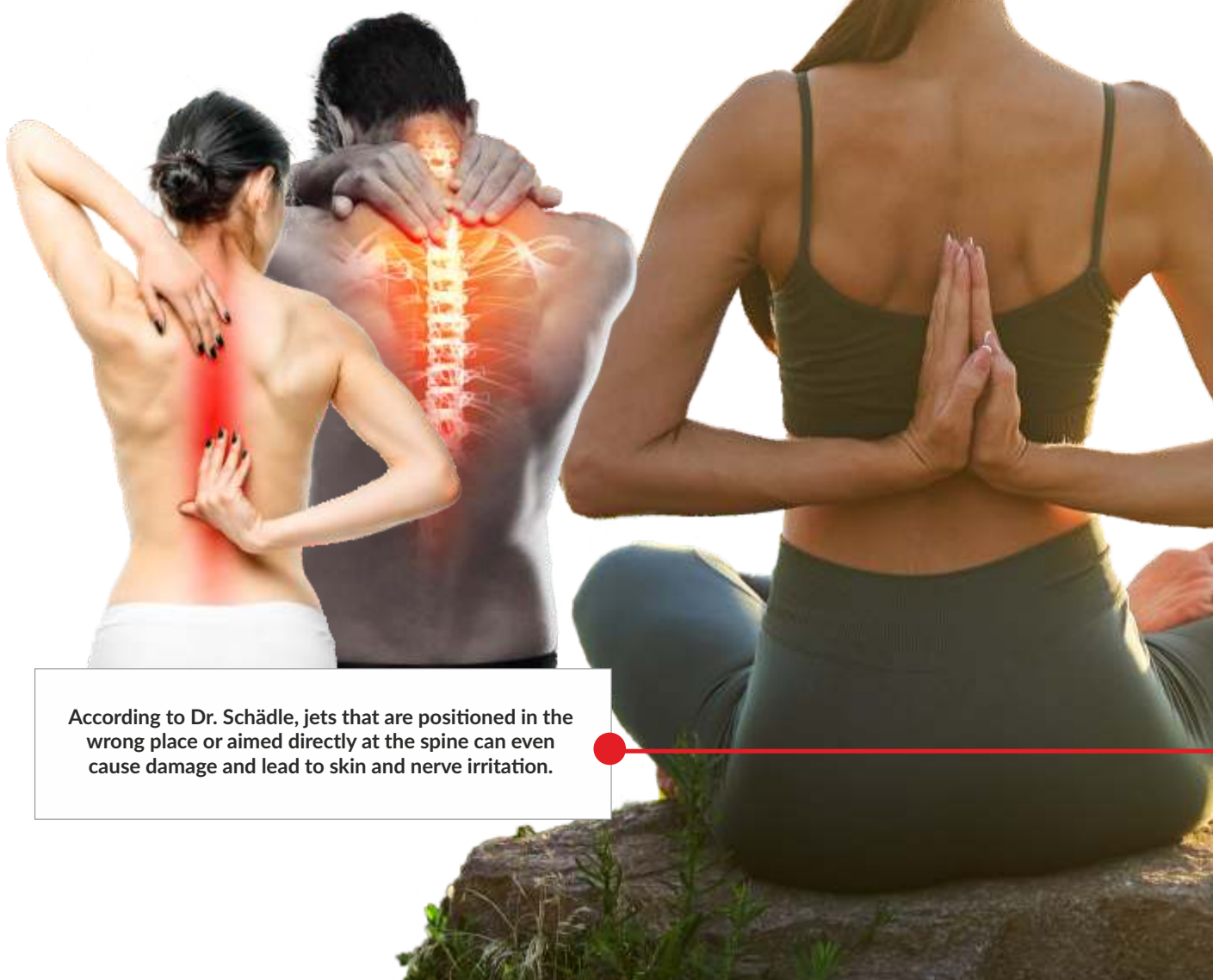

According to Dr. Schädle, jets that are positioned in the wrong place or aimed directly at the spine can even cause damage and lead to skin and nerve irritation.

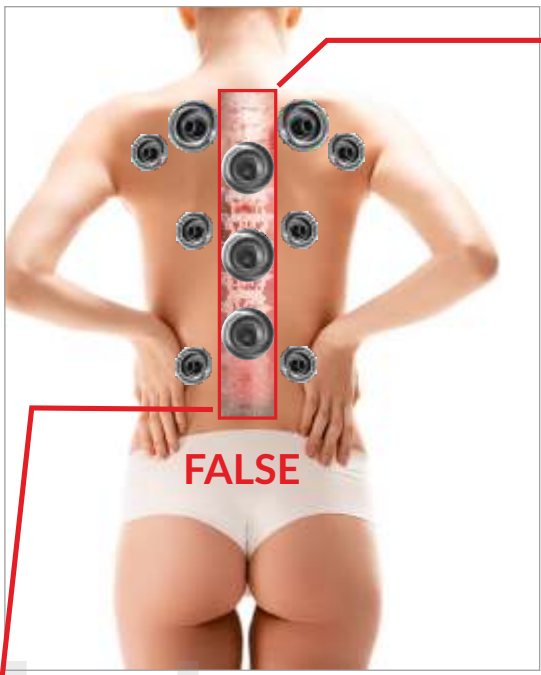

**Health Harmful to health & unpleasant**

When it comes to the ergonomics of massage seats and loungers, it is important to ensure that none of the jets are aimed directly at the spine. Experienced doctors recommend hydrotherapy in a whirlpool and at the same time warn against incorrectly positioned whirlpool jets which are aimed directly at the nerve cords of the spine. Never use a hot tub with even one jet pointing directly at the center of the spine, as this could damage your health! So never buy or use a whirlpool tub with one or more jets aimed directly at the spine.

The only right way if you value your health!

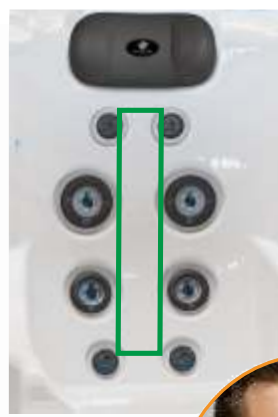

BACKBONE

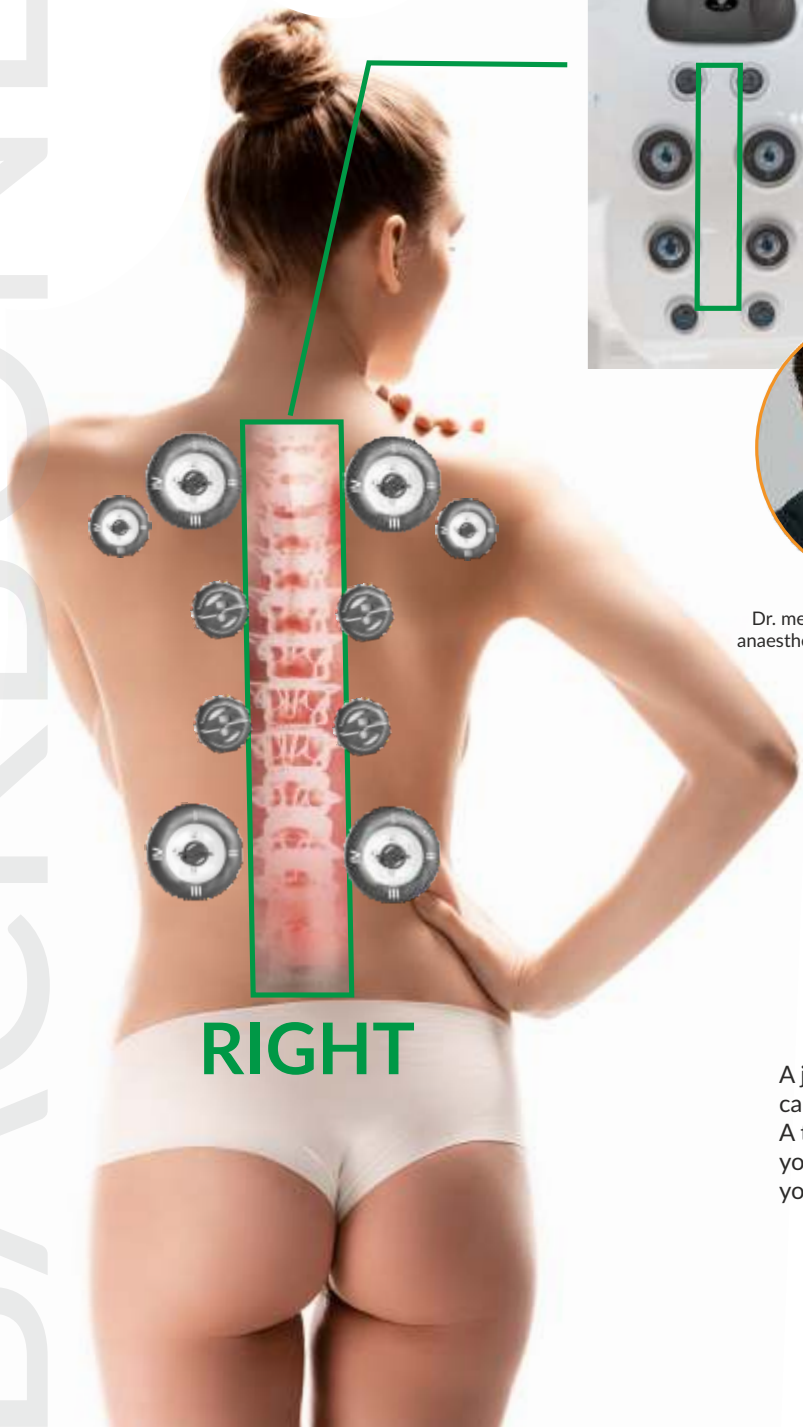

Dr. med. Bertram Schädle Specialist in anaesthesia, intensive care and preclinical emergency medicine.

A jet that you don't have can't massage you!  
 A type of massage that you don't have can't help you either!

(Otmar Knoll, Director Whirlcare Industries)

# the hydromassage

Understanding anatomy. Position jets correctly!  
Wellness meets health promotion

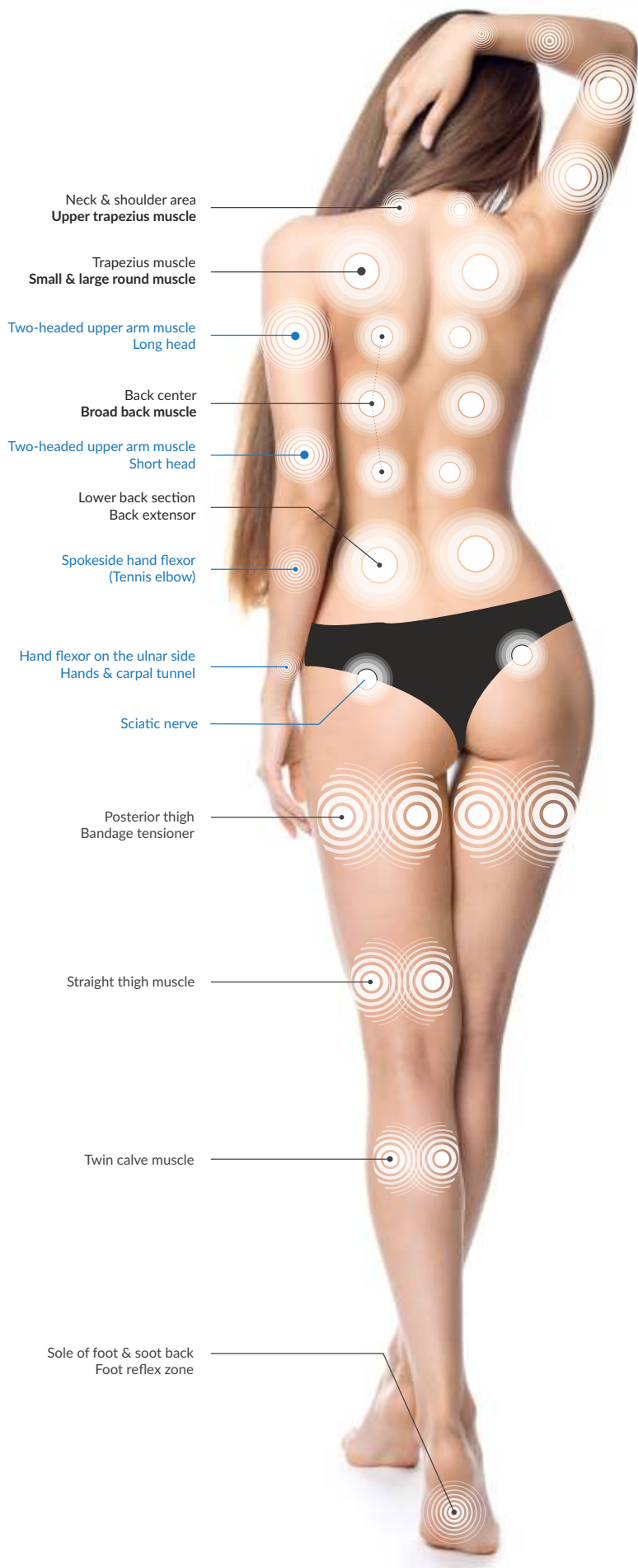

Neck & shoulder area  
Upper trapezius muscle

Trapezius muscle  
Small & large round muscle

Two-headed upper arm muscle  
Long head

Back center  
Broad back muscle

Two-headed upper arm muscle  
Short head

Lower back section  
Back extensor

Spokeside hand flexor  
(Tennis elbow)

Hand flexor on the ulnar side  
Hands & carpal tunnel

Sciatic nerve

Posterior thigh  
Bandage tensioner

Straight thigh muscle

Twin calve muscle

Sole of foot & soot back  
Foot reflex zone

## Hand and carpal tunnel

The carpal tunnel is a channel in the area of the carpus that is bounded by bone and connective tissue. Tendons and the median nerve run through the carpal tunnel. This nerve controls sensitivity and mobility.

## Upper and lower arm muscles

The arm muscles include a good twenty muscles, most of which are located in the forearms. However, the most prominent representatives, the biceps and triceps, are found in the upper arm. The two antagonists enable the arms to bend and stretch.

## The back muscles

The local back muscles are responsible for stabilizing and straightening the spine. The migrating large back muscles, which cover the lower back area, lend stability to the entire musculoskeletal system and enable shoulder and arm movements, among other things. Widespread deformities of the back are bends and misalignments, which are often accompanied by tension in the shoulders or neck. They are often the result of one-sided posture, especially when sitting for long periods or working at a computer screen without change of position, or even in unfavorable sleeping positions

## Sciatic nerve

The strongest nerve in the human body. The sciatic nerve originates from a network of nerves that emerges from the spine below the fifth lumbar vertebra. The origin of the nerve is therefore in the lower back. A lack of movement or unbalanced movement can lead to tense muscles pinching the sciatic nerve and causing pain. The reason for this: frequent sitting

## Upper & lower leg muscles

Among the thigh muscles, the quadriceps stand out in particular. It covers almost the entire front of the thigh. Its tasks include stretching and stabilizing the knees. The lower leg muscles can be divided into the anterior and posterior muscles, which consist of extensors and flexors. The calf muscles are well known to every athlete, especially soccer players.

## The foot reflex zones

Reflex zone therapy is based on a holistic view of the body. According to the theory, all parts of the body are interconnected. The human body is reflected in the foot. The beneficial effects of a foot reflex zone massage are manifold: the form of therapy has a relaxing effect, stimulates blood circulation and promotes the body's self-healing powers. It can therefore not only contribute to regeneration in stressful everyday life, but also provide lasting relief from acute and chronic pain.



# The massage zones

With each of our Whirlcare® pools, you can be sure that the jets are anatomically correctly positioned and work directly on the muscular reaction points and problem areas - for improved health and well-being.



## Hand and carpal tunnel

Our hands are particularly sensitive, and yet they have to work hard every day. Integrated hydrojets for hand massage offer an intensive pampering program that can relieve pain. Many customers use the massage to prevent carpal tunnel syndrome or to support healing and rehabilitation after an operation.



## Neck and shoulder area

Muscle tension in the neck is stubborn and often the cause of headaches. Targeted hydromassages in the neck area can relieve this tension and even alleviate migraine symptoms. The muscles in the shoulder area tend to tense up under stress. This often leads to pain in the shoulders and upper back. The hydrojets in your whirlpool gently massage these sensitive areas, improve circulation and can even relieve deep-seated tension.



## Back, hip and breech area

Lack of exercise and prolonged sitting often cause severe tension in the large muscle cords to the right and left of the spine. This can lead to a variety of other health problems. An effective combination of different jets pleasantly stimulates your back and provides pleasant relaxation. Sitting for too long quickly leads to tension in the muscles of the hips, thighs, intervertebral discs and buttocks. The jets at the side of the seats stimulate precisely these muscle areas and provide pleasant relief.



## Chest and abdominal area

Abdominal and chest pain without clinical findings is often dismissed as psychosomatic. However, tension in the muscles and connective tissue / fascia can actually be the cause. For this reason, some Whirlcare® models also have a Vulkanjet, which also massages the abdominal, chest and shoulder area by leaning over it.



## Sole & arch of the foot

Many nerve cords end in the feet. For this reason, tired and aching feet often affect our overall well-being. The theory of foot reflex zones assumes that there are connections between the organs and parts of the body and certain areas of the foot. Stimulating the corresponding foot zones is intended to stimulate blood circulation and the body's self-healing powers. The Whirlcare® jets massage the soles of your feet in the upper and lower areas, which can lead to relaxation throughout the body.



## Legs & calves

Tension and stiffness in the legs and calves, for example due to intensive sport or wearing high heels, are not only unpleasant but can also cause painful muscle cramps. Heat and gentle massage jets have a soothing effect and can provide relief.



Dr. med. Bertram Schädle  
Specialist in anaesthesia, intensive  
care and preclinical emergency  
medicine.

**VARIOUS**  
HYDROJET

The new Whirlcare® Various Hydrojet jet meets all the requirements for a health-promoting and soothing hydromassage. Read all about the technical components and different types of massage in the chapter "Various hydrojets"

# 9 Die 9 Whirlcare® Benefits

The health benefits with a Whirlcare® hot tub



### Improvement of sleep

Many people complain about sleep disorders for various reasons. Numerous studies indicate that relaxing hydromassages can effectively alleviate sleep disorders and have a positive effect on the psyche.



### Release tension & hardening

Sore muscles, incorrect strain and poor posture can lead to hardened and tense muscles, among other things. However, what begins as seemingly harmless tension can become a serious problem and chronic pain if it is not resolved. Hydromassage stimulates the muscles, which can also release stubborn tension and hardening.



### Pain relief for chronic pain

Regular treatment with hydromassage can often help people with persistent pain to break through their perception of pain and thus enable further movement therapies. Thanks to the soothing warmth of the water makes the full-body hydromassage particularly pain-relieving and successfully relieves stubborn muscle tension.



### Increase blood circulation

With the right Various Hydrojet setting, the water jet penetrates into the deep tissue layers, stimulating blood circulation and cell metabolism in the tissue. Increased blood circulation the treated regions are better supplied with nutrients and waste products are removed more quickly



### Support of wound healing

Hydromassages can help to optimally support the skin on its wound healing journey. Regular massage sessions stimulate blood circulation in the treated tissue, which supports the regeneration of the injured skin and thus the wound healing process. Scarring, for example, can be significantly reduced, which is desirable both functionally and aesthetically. The flexible Various hydrojet settings are also suitable for processing scar tissue, among other things.



### Strengthening the immune system

Regular massages have a positive impact on general body awareness and stimulate the metabolism and immune system. With some special massage techniques, such as foot reflex zone massage, stimuli reach the brain and from there to the various organs through targeted pressure via the skin, muscles, nerves and the blood and lymphatic system.



### Purification / anti-cellulite

Manual lymphatic drainage can help people in whom the fluid in the lymphatic system is not being removed normally due to a recent trauma or illness. In addition, lymphatic drainage in combination with a powerful individual hydromassage is very effective in combating cellulite. Especially with subsequent Skinoxyform application



### Reduction of stress & anxiety / psyche

A large number of clinical studies have shown a positive effect of hydromassage as a therapy supplement in the treatment of depression or anxiety disorders. Skin contact, metabolic stimulation and relaxation have a positive effect on mental health and body awareness. With any type of massage, the body reacts to the mere touch of the skin by releasing the hormone oxytocin, which creates positive emotions towards people. The brain also releases endorphins, the body's own happiness hormones, during a massage.



### Improving the appearance of the skin / anti-psoriasis / anti-acne

The Skinoxyform\*\* oxygen enrichment of the water enables you to rest in a sea of millions of tiny oxygen particles, allowing you to specifically prevent or treat skin impurities such as psoriasis (dandruff) or sebaceous gland blockages, cellulite, stretch marks, wrinkles, scars and other skin problems and make the skin smoother.



Prevention is better than cure. Healing can be promoted.

**Whirlcare® takes care of both!**

So, let's take the Whirlcare<sup>®</sup> hot tub  
apart in terms of

# PERFORMANCE



*Future*

**XE Exchange Efficiency**  
The Whirlcare<sup>®</sup>  
Energy-safing management-system





Any manufacturer who claims to build equivalent or better whirlpools than Whirlcare® and can justify this objectively will be met with an open communication policy. We counter anyone who dares to make a comparison with a multitude of equally factual arguments. Because we are convinced that all facts and advantages count in such a competition - not just individual aspects

**Philosophy of the Whirlcare® XE models**  
Exchange Efficiency / Whirlcare® Energy-management-system

# Smart & energy-efficient



Whirlclear® filter system  
pure water

Invisible  
sound system

Illuminated  
waterfall

Various Hydrojets

Aromakur  
Injector

Smart-Spa-Control  
Display

HeatEnergyPump  
including heat pump bypass.  
Standard in all XE-models

# Die Whirlcare® massage revolution

Individually adjustable massage head



4-way adjustable  
massage head



Intensity  
setting

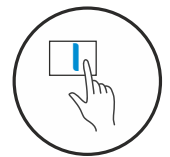

Touch indentation  
at the start position  
(Braille)



## The underwater massage revolution

Designed, manufactured and made by Whirlcare®

## Patented world first from Whirlcare®

The hot tub and swim spa jet with individually adjustable massage head, strength regulation and up to four different massage types - all in one jet. This is a world first and absolutely unique. Discover the revolutionary world of VARIOUS hydro jets from Whirlcare - a ground-breaking innovation that is unique and incomparable worldwide. For the first time in a Whirlcare® hot tub, we offer you thousands of massage settings with variable intensity to take your wellness experience to a whole new level. What makes our VARIOUS™ hydro jets so special? They are made of 100% recyclable plastic [and not environmentally harmful PVC or chrome etc.], making them the most sustainable hydro-jets on the market. Thanks to their unique design without moving parts such as ball bearings, they are much more durable and do not require any environmentally harmful adhesives with plasticizers during assembly. Incidentally, the Various Hydrojet jet is the first hot tub jet in the world that can also be installed by a robot.

Thanks to our patented technology, you can enjoy up to 4 different types of massage with a single jet. And best of all, each jet is individually and continuously adjustable in strength to suit your personal needs. No other manufacturer offers you this versatility and customization options. The VARIOUS™ hydro jets are recommended by doctors for their therapeutic effect. They are designed to provide you with an optimal massage experience while being energy efficient. 100% Made in Germany stands for the highest quality and precision. Our VARIOUS™ hydro jets were developed by Whirlcare®, doctors and fluid experts and are manufactured in Germany. What makes them even more special is that they are assembled by people with disabilities in collaboration with the German Lebenshilfe organization, which contributes to inclusive and socially responsible production.



The VARIOUS™ hydro jets are not only functional, but also aesthetically pleasing. Each jet can be illuminated with LEDs to enhance the colored light therapy and create a pleasant atmosphere or beautify your wellness oasis. In addition, our VARIOUS™ jets are characterized by their low susceptibility to repairs, as they function without the addition of air. Sealing is provided by a high-quality special rubber seal, which ensures reliable and long-lasting performance. Experience the unique versatility and quality of VARIOUS™ hydro jets. Pamper yourself with individually adjustable massage types in different strengths. Immerse yourself in a world of relaxation and revitalizing therapy.

- Up to four different types of massage in one nozzle. No additional air admixture is required.
- Lower water pressure, less water flow and therefore a lower pump output required ensure permanent energy savings of up to 63% during operation.
- Each Various jet can be individually adjusted in strength and has different hydro massage modes simply by turning it. It's all in one Various Hydrojet
- Development and production 100% Made in Germany. Only easily recyclable ABS material is used. No moving parts or ball bearings.
- Insensitive to calcareous water or water contamination. Easy to clean and more durable than conventional jets
- The Various Hydrojets make the Whirlcare® the quietest hot tub in the world without noise from the air



# One jet. Countless possible combinations

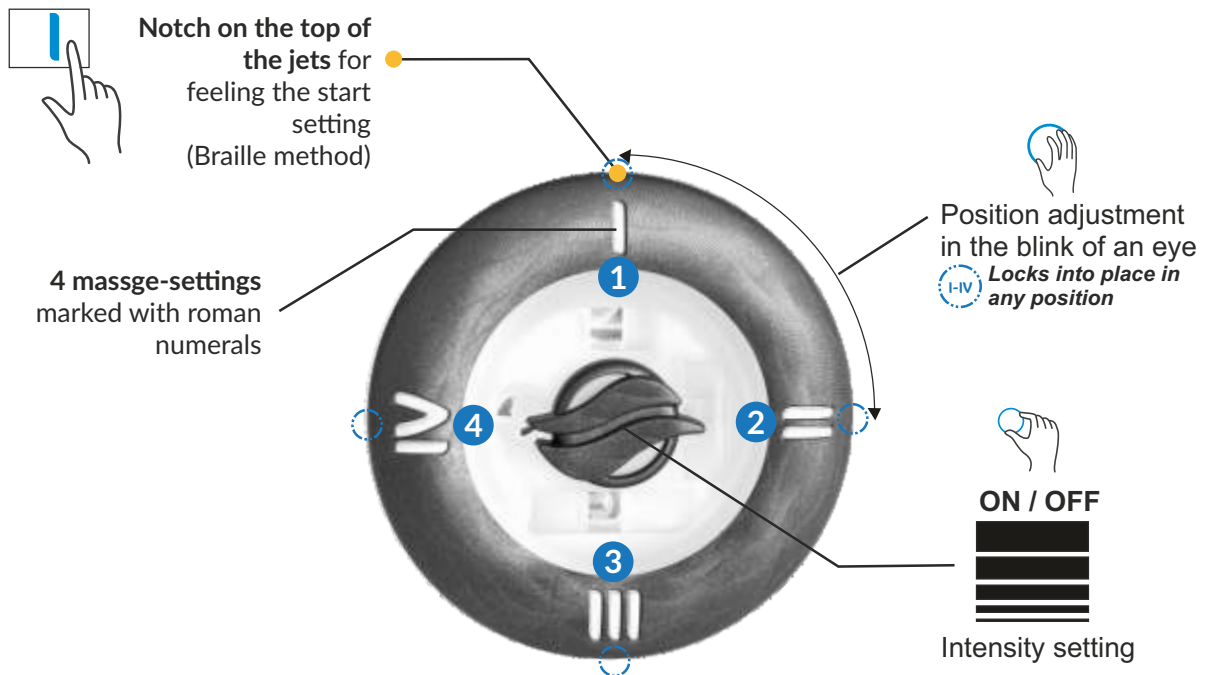

What can the Various Hydrojet do for your health?

## 1 Water-Shiatsu (Watsu) Connective tissue / fascia massage



Water Shiatsu is an alternative medical massage and movement therapy. It is based on the principles of Zen Shiatsu. With the additional effect of warm water, the relaxed feeling can become much deeper. The areas of application of Watsu include mental, physical and spiritual tension as well as blockages; these are to be released through the treatment. It can also stimulate the metabolism, relieve pressure on the joints and promote peripheral circulation.

## 2 Swedish Massage

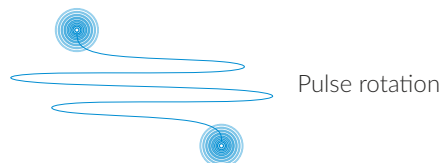

A Swedish massage is the classic form of massage. It is mainly used on the back, but can also be performed as a full body massage. The areas of application are very diverse and help to relieve hardening and tension. Swedish massage is also used to treat sensory disorders, paresis and psychosomatic complaints.

## 3 Deep Tissue Massage Lymphatic drainage

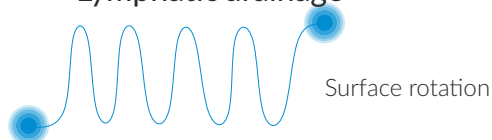

The term "deep tissue" refers to the deep connective tissue. This type of massage is a deep tissue massage that has a positive effect on chronic muscle tension and scars. The term "deep tissue" refers to the deep connective tissue in particular. It also relieves cramps. Deep tissue massage can also provide relaxation and reduce stress.

## 4 Sport Massage Anti cellulite massage



A sports massage is a supplement to the classic massage. It is used before and after sporting activities. The main areas of application of sports massage therefore include loosening the muscles and improving the oxygen supply. In addition to athletes, people who suffer from back pain, neck pain or stress due to incorrect sitting posture, long periods of driving, working at a desk or computer can also benefit from a sports massage, as the massage can specifically treat the resulting adhesions and tension.



**VARIOUS**  
HYDROJET

MASSAGE  
RENDERWATER  
UNDERWATER

Effective hydromassage from water without adding air! Hot tub experts claim that the Whirlcare® XE models have the best massage and are the quietest whirlpools in the world

Three sizes installed

- Individually adjustable
- Intensity regulation
- No moving parts
- Longer service life
- Insesitive to limescale

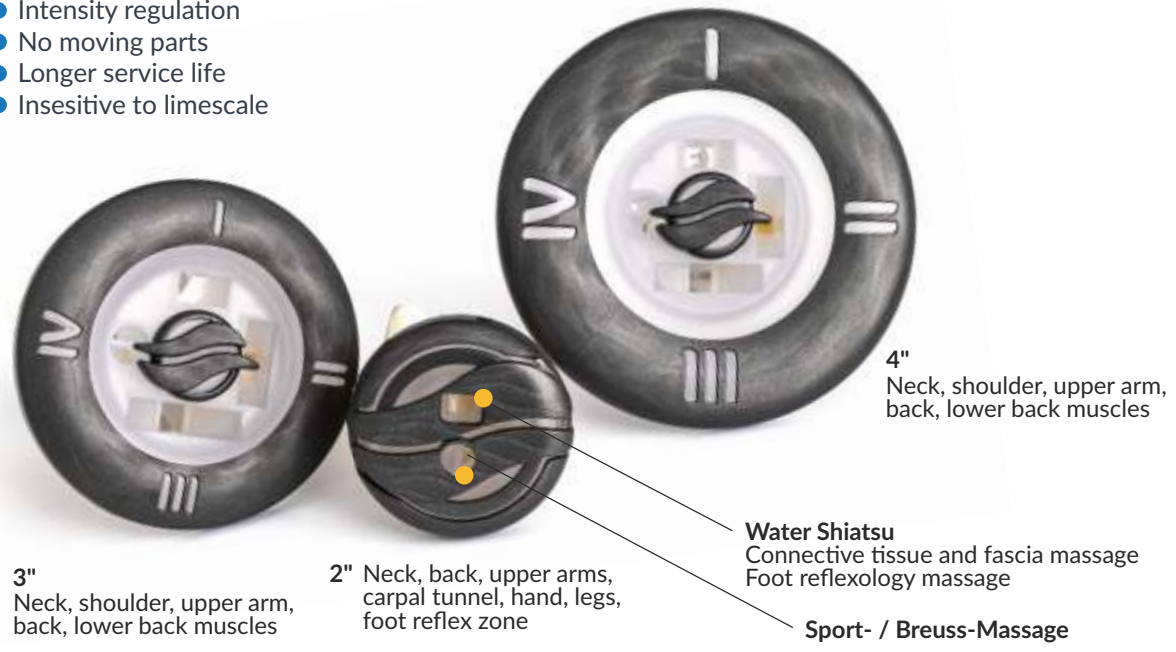

The Various Hydrojets are an essential component of the Whirlcare Energy-safing management-system 

# The Whirlcare® hot tub pumps

Energy saver & performance champion

## HYDR POWERPUMP



### Efficient & quiet

Discover the impressive performance and energy efficiency of the specially developed pumps from Whirlcare®. Our whirlpools are powered by innovative pumps that deliver outstanding performance and efficiency. Thanks to their unique design and technology, our pumps offer an incredible 25-28% increase in performance compared to conventional pumps. Or save up to 25-28% on energy costs with Whirlcare® with comparative performance. This means you can enjoy a powerful and intense massage experience without compromising on energy efficiency. But that's not all. Our HydroPowerPump® is not only characterized by its impressive performance, but also by its remarkably low noise level. At just 49 dB, it is one of the quietest pumps on the market. Immerse yourself in a world of relaxation and enjoy your whirlpool experience without any disturbing noises in the background.



At this performance level, the 2.2 KW (3 hp) pumps used in the Whirlcare® are clearly superior to the average massage pumps with a pressure of 1.9 bar and a maximum flow rate of 61,200 liters per hour. A comparison with the competition shows that more powerful pumps (e.g. with 2.5 KW or 3.38 HP) must be used here to achieve the same water flow rate.

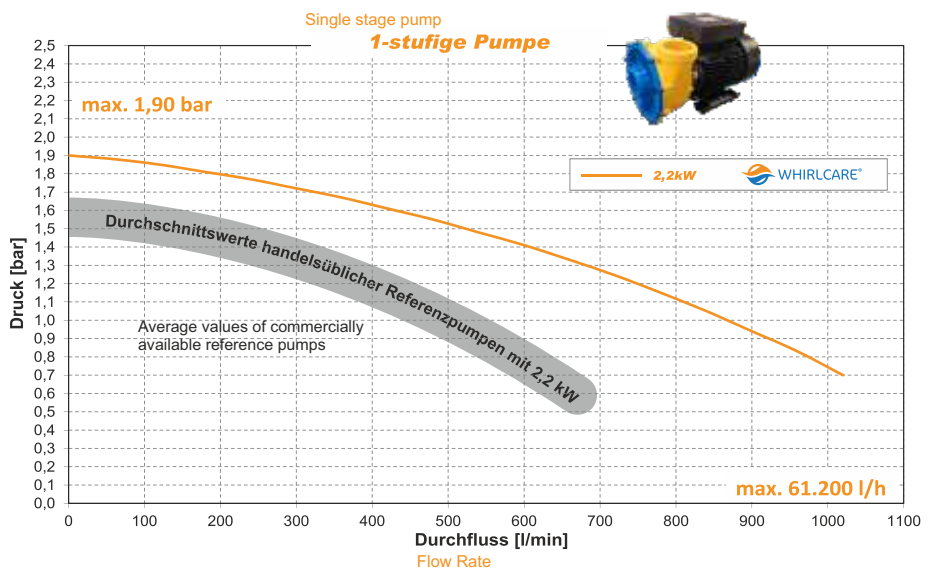

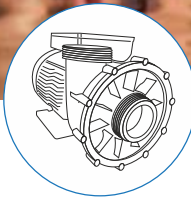

## Separate circulation pump

Unsurpassed cleaning performance

Cleaning the water in a whirlpool is crucial to ensure a hygienic and inviting bathing experience. Whirlcare® uses innovative circulation technology that enables fast and thorough cleaning with minimal energy consumption. By combining horizontal and vertical flows and a higher flow rate, optimum pool hydraulics are achieved. The result is effective removal of dirt particles and impurities that could cloud the water. With Whirlcare® you will always enjoy crystal clear water in your hot tub. What makes our circulation technology really impressive is its enormous output of 72 liters per watt. With only 200 watts and daily system/line cleaning by the HydroPowerPump in combination with our Whirlclear - pure water filter system, the entire water content is circulated more than 48 times a day, with only 2x2 hours of running time. In addition to superior cleaning performance and efficiency, you also benefit from lower energy consumption. Our technology was developed to optimize energy consumption and thus offer you cost-saving benefits.

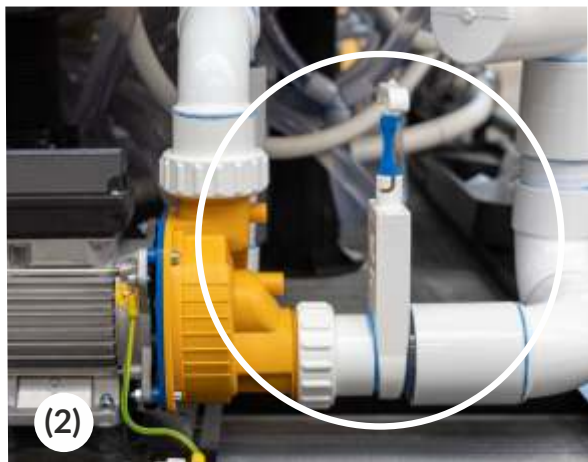

## Reduced vibration & sound insulation

Each pump stands on a mounting plate with rubber buffers (1) for sustainably lower vibration and higher sound insulation. There are so-called shut-off valves (2) in front of and behind each HydroPowerPump®, which make it easy to replace the pump - without having to change the whirlpool water. This sophisticated design makes it easy to carry out repairs or maintenance work. You do not have to take your whirlpool out of service for a long period of time, even when replacing the pump. This saves time and money. And we have also thought about draining the pump. With our innovative cartridge connection, you can drain the pump easily and without time-consuming removal. Draining the pumps is particularly important if you want to winterize your hot tub to prevent frost damage. With the cartridge connection, draining is child's play. Simply connect a hose to the connection and drain the water. No tedious removal of the pump, no complicated procedures. With Whirlcare®, draining your HydroPowerPump® is a simple and time-saving process. You can rest assured that your pump will be completely drained and protect you from possible frost damage. If you want to take your whirlpool out of operation over the winter, it must be drained completely - including pipes and pumps - to prevent frost damage

Facts don't disappear  
just because you  
ignore them

(Sam Ewing)







## Performance comparison

These figures make competitors envious

Facts & figures in connection with the Various Hydrojets

Determine the water flow rate in liters per hour to ensure full functionality. Higher pressure (bar) does not bring any significant benefits for the hydromassage. If the pressure (bar) is too low, the massage is either no longer functional or no longer available, as each nozzle requires an individually determined water flow rate in order to perform its assigned task. E.g. double rotor nozzle no longer rotates if the pressure is too low or the water flow rate is too low.

### Required water flow rate for a conventional whirlpool, e.g. with 60 jets

Jets: CMP, Balboa, Waterway etc.	Piece / Number	Liter/h - flow rate per jet (approx.)	Liter/h - Total flow rate (approx.)
2 inch	38	1.378	52.364
3 inch	10	1.890	18.900
4 inch	12	2.215	26.580
<b>Total</b>	<b>60</b>	<b>5.483</b>	<b>97.844</b>

### Required water flow rate for a Whirlcare® whirlpool with 60 Various Hydrojets

Whirlcare VARIOUS HYDROJETS	Piece / Number	Liter/h - flow rate per jet (approx.)	Liter/h - Total flow rate (approx.)
2 inch	38	613	23.294
3 inch	10	637	6.370
4 inch	12	655	7.860
<b>Total</b>	<b>60</b>	<b>1.905</b>	<b>37.524</b>

### Required number of pumps due to the required flow rate

2.2 kW / 3.0 HP pump capacity with correspondingly used jets

Comparison 2,2kW (3,0HP) single stage pump	Flow rate in Liter with 1,9 bar (27,55 psi) approx.	Pump flow rate performance	Number of pumps required for conventional jets (97.844 Liter/h)	Number of pumps required for VARIOUS HYDROJETS (37.524 Liter/h)
LX Pumpe	38.100	62,25%	3	1
Gecko	38.611	63,08%	3	1
Balboa	48.000	78,43%	2	1
Waterway	53.611	87,59%	2	1
<b>HydroPowerPump</b>	<b>61.200</b>	<b>100,00%</b>	<b>2</b>	<b>1</b>

Savings  
**-63%**  
Increased performance  
**+28%**

By using a HydroPowerPump + 28% more power, and the VARIOUS Hydrojets - 63% more water flow required, it is possible to save energy compared to conventional jets or pumps and thus use more massage jets for physical well-being by using less energy.

The HydroPowerPump is an essential component of the Whirlcare Energy-safing management-system 



**SMARTSPA**  
CONTROL

 WHIRLCARE® XE

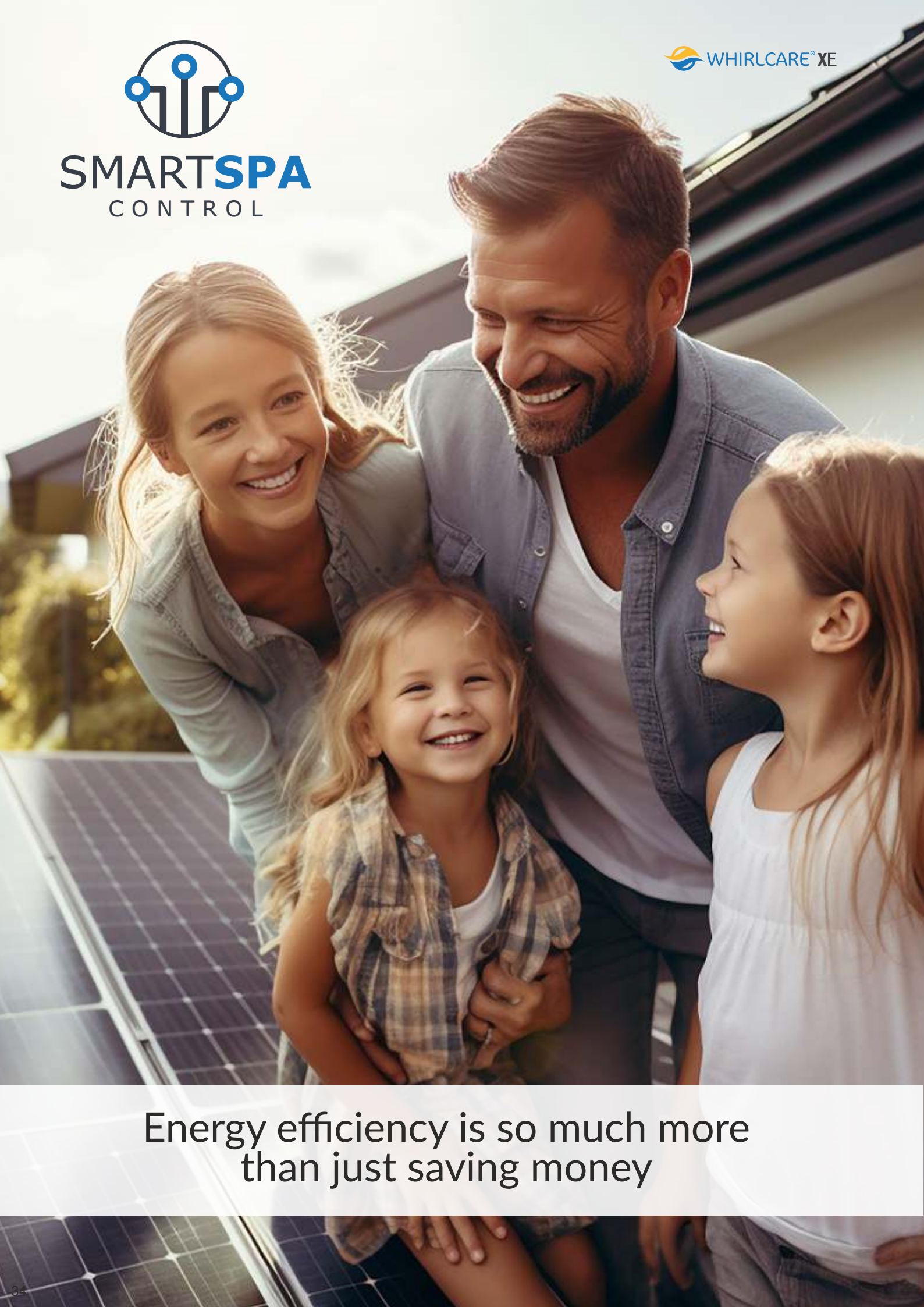

Energy efficiency is so much more  
than just saving money

# The Whirlcare® hot tub control unit

Technology that inspires everyone

## SMART. INTUITIVE. EASY TO USE.



## Smart Spa Control

Full control with AI-supported hot tub/spa control

The new alternative control system for hot tubs and SwimSpas offers innovative and high-quality control systems and additional modules. This leads to energy savings, lower operating costs and environmental protection. The superior features include maximum energy efficiency, intelligent and customizable software and stable product reliability. Compared to previous control systems, it is years ahead. The intelligent smart software monitors the spa and usage habits to ensure lower operating costs. It also offers various energy saving features, including a heat pump interface to reduce operating costs by up to 75%. The variable heater minimizes heat loss and adjusts the heat output to the power supply.

# Superior Smart-Spa functions

Intelligent, variable and absolutely energy efficient

The control unit enables wireless remote control of the hot tub via your cell phone, voice control with Google Assistant or Alexa and push notifications for error codes. It offers worldwide remote technical support and intuitive menus. The HD sound system with Bluetooth connectivity allows you to stream audio/music to the spa and control it via Wi-Fi. An intelligent control system optimizes the heating cycles, avoids unnecessary switching on and off of the filter pump and enables savings of approx. 15% of the daily power consumption. The control system takes into account the pump running time during heating, resulting in energy savings of 10%. Programmable filtration and sleep timer offer additional energy efficiency. Finally, the SmartControl control system adapts to all installations and does not require different models. It can be adjusted on site to optimize power consumption.



The first "AI" hot tub control unit that thinks for itself and uses user behavior to exploit the best possible energy-saving potential

## Smart Link Wifi Control

With the SmartLink Wi-Fi module and SmartLink app, you can connect to and remotely control your spa anytime, anywhere using an Apple® or Android™ device. The SmartLink module connects to any SV controller model and then uses your home Wi-Fi network to facilitate communication between the app server and the spa. The SmartLink app becomes a mobile, wireless remote control for your spa, allowing full control of all settings and accessories, including pumps, blowers and LED lights.

- AI-powered, intelligent smart software monitors your spa and your usage habits to ensure the lowest possible operating costs
- Additional energy savings through various functions that enable you to make real financial savings
- Maximum energy efficiency, stable product reliability. Intelligent and customizable settings for connections and software
- Can also be operated with your own photovoltaic system

The Smart-Spa\_Control is an essential component of the Whirlcare Energy-saving management-system 

\*external App-Download required  
 \*\*SmartSpaControl only compatible with Whirlcare® HeatEnergyPump  
 \*\*\*Voice Control devices (Alexa, Google Assistant) must be installed externally

The Whirlcare® XE  
smart technology combines  
sustainability and energy efficiency  
with health promotion

*Life Quality*

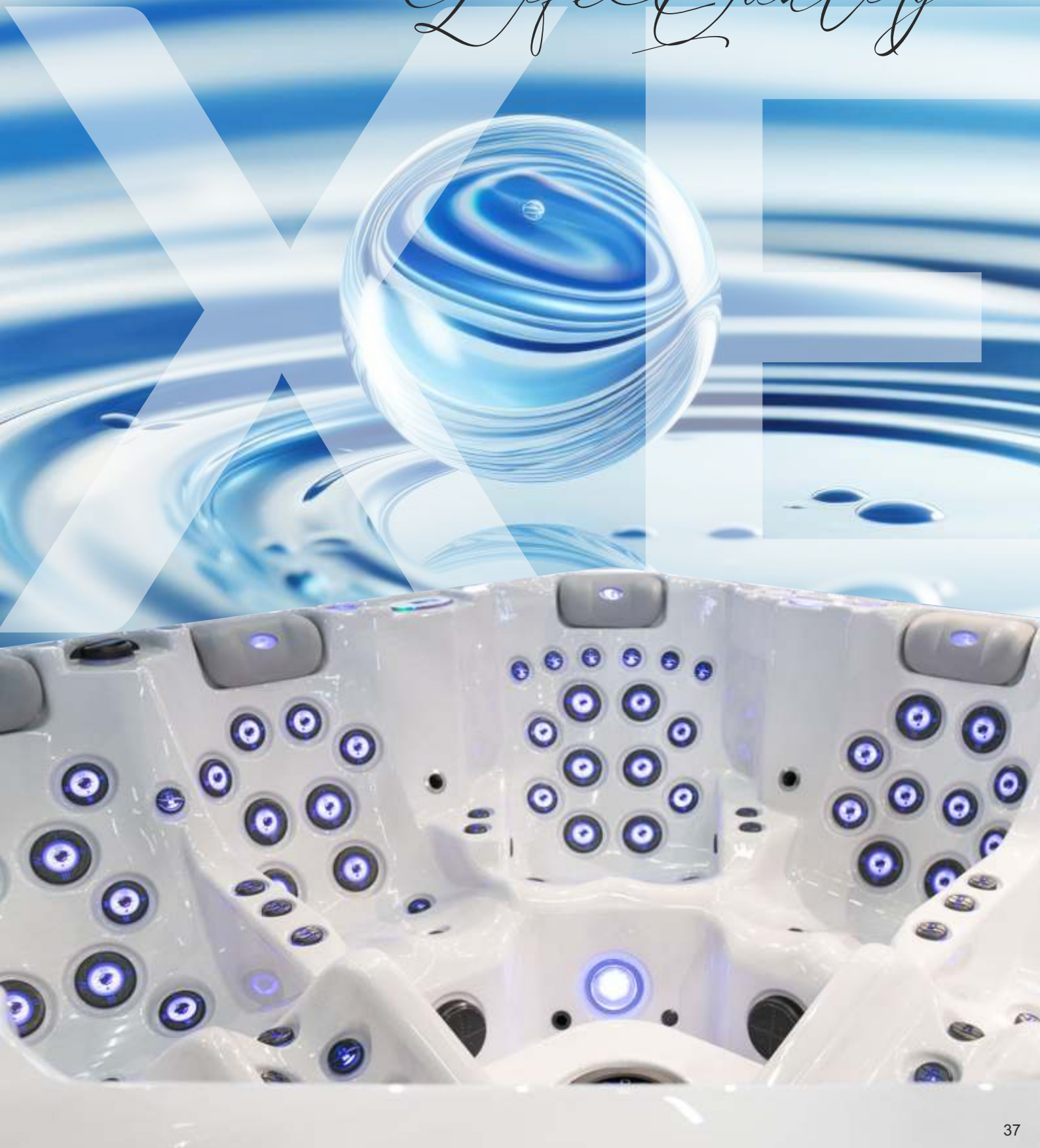

# HeatEnergyPump connection

Heat in winter, cool in summer



The SmartSpaControl has a special extension module for the seamless integration of an energy-efficient HeatEnergyPump into the hot tub's heating/cooling system. The heat pump interface revolutionizes hot tub temperature control. We can now offer both automatic heating and cooling of the hot tub water (from 10°C - 40°C), which can be conveniently controlled via the keypad on the hot tub. The greatly reduced heat recovery times can be further shortened with the exclusive rapid heat-up cycle options.



## Bypass connection

Standard in every Whirlcare XE-model

The HeatEnergyPump heat pump technology maintains the water temperature of your spa while consuming around 75% less energy than a conventional electric heater, resulting in an environmentally friendly and amazingly cost efficient spa experience. When the heat pump is connected, it is automatically controlled by the Smart Spa Control. When the temperature is adjusted, the control system automatically responds and uses the heat pump to heat or cool to regulate the water to the newly set temperatures. With solid-state diagnostics and real-time heat pump monitoring, the SmartSpaControl control system takes care of all the heat pump's needs. As a result, the HeatEnergyPump can ensure long-term reliability with minimal running costs. Our heat pumps use refrigeration technology to extract heat from the air (even when it is cold) and use a very small amount of energy to drive the fan motor and compressor. Compared to gas or electric heaters, a heat pump uses only a tiny fraction of the energy to generate the same amount of heat. It uses up to 75% less energy than an electric spa heater. For every 1 kW of electricity consumed by a standard heating element, it emits only 1 kW of heat. In comparison, the HeatEnergyPump heat pump produces up to 5.5 kW of heat for every 1 kW of electricity consumed by the SHEP-WCI-55P 5.5 kW, i.e. it produces up to 4.5 kW of heat for free!

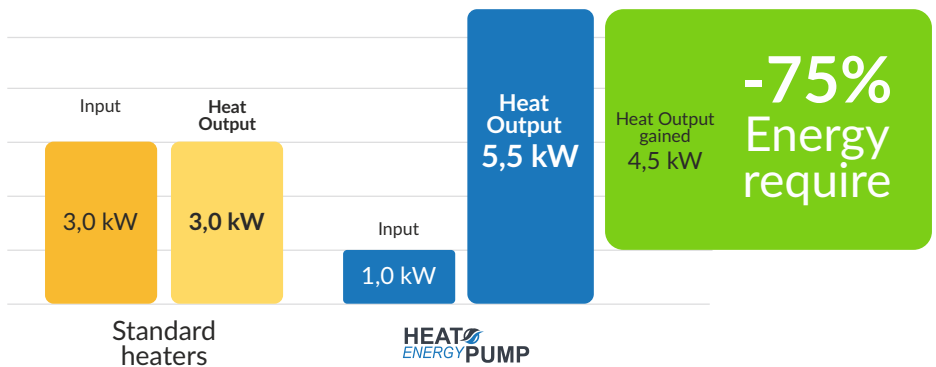

- Reduced electricity bills Significantly
- faster heat-up times
- New refrigeration heat pump for sub-zero temperatures down to -25°C
- Lower carbon emissions
- corrosion-resistant
- Simple plug-n-play installation
- Also suitable as a cooling spa



# Compatible for solar thermal with buffer tank

Smart technology enables heating via photovoltaic system



## Power Safe

Dynamic thermal tuning

No two hot tubs are the same when it comes to thermal performance and heat storage. Day after day, season after season, the control system automatically adapts and adjusts to the thermal characteristics of your spa and its environment to recognize the need for thermal cycling. Dynamic Thermal Tuning contributes to optimal heat regulation while minimizing power consumption, resulting in lower daily operating costs. In conjunction with the PowerSafe setting, enjoy the benefits of greatly reduced off-peak electricity rates to lower your spa's daily operating costs. PowerSAVE technology controls automatic power consumption to off-peak times while maintaining water temperature and daily filtration times. Simply activate PowerSAVE and set the tariff times and you can start saving money.



## Power Smart

Sophisticated real-time current measurement and variable heating technology enable the Smart Spa Control to make optimum use of any available energy source. Multi-phase capable, the control offers flexibility when connecting to mains power supplies and supports connection to 1, 2 or 3 phases from 10 to 60A. Added to this are the many exclusive SmartSpa energy-saving functions, such as the special HeatEnergyPump heat pump interface. With AI-powered Dynamic Thermal Tuning and user-defined heating modes, SmartSpaControl stands out from all competitors as the most energy efficient spa control on the market - namely the one with the lowest daily operating costs.



## Variable heating

The SmartSpaControl control modules feature innovative variable technology. With real-time current detection, the variable heater automatically adjusts its power level (kW) to the available residual power (amperage), taking into account any additional operating loads (spa massage pumps or air blowers). You can take advantage of a larger heater for faster heat recovery and be assured that the same heater will automatically reduce its size to maximize heat output when loads are in operation. The variable heater is controlled automatically and does not need to be set separately.

The HeatEnergyPump in conjunction with the Smart-Spa-Control is an essential component of the Whirlcare Energy-saving management-system



# Professional water disinfection

The UV-Light & ozone generator

## INNOVATIVE FILTER TECHNOLOGY



UVZONATOR



Our ozone and UV combination unit is the most effective system of its kind and ensures effective and sustainable disinfection of the water. By using these innovative technologies, you reduce the need for chlorine and minimize the use of other chemicals by an impressive 80%. You not only enjoy clean water, but also a natural and gentle treatment that is kind to your skin and your health. The combination of ozone and UV not only kills bacteria and germs, but also prevents the growth of algae. The result is crystal-clear and hygienically pure water in which you can relax without any worries. Whirlcare - your partner for innovative whirlpool technologies. Discover the benefits of the ozone and UV combination and experience the perfect balance between purity and relaxation. The UV light can break the molecular bonds within the DNA of microorganisms and produce thymine dimers in their DNA, rendering them harmless and preventing them from growing and multiplying. This ultraviolet water purification renders organic pollutants harmless when the water passes through the treatment chamber and thus the UV light. The light deactivates the microorganisms. It is not for nothing that UV light is also prescribed for disinfection in hospitals and public baths.

It is not without reason that UV light is also prescribed for disinfection in hospitals and public baths. Viruses, bacteria, microorganisms and even the COVID-19 virus are destroyed. Thanks to the combination of UV light and ozonator in our Whirlcare® whirlpools, corona doesn't stand a chance either. The additional water disinfection reliably kills germs, viruses and bacteria, thus reducing the need for water care products such as chlorine, active oxygen, bromine or bio-based additives. The ozone system ensures natural disinfection of the water and pipe systems. Ozone is an unstable molecule consisting of 3 oxygen atoms and is one of the most effective antibacterial agents: on contact with water-wetted substances, it transfers its third atom to this material.

When you step into your Whirlcare®, you can look forward to crystal-clear, hygienically perfect water. The multi-stage filter and water purification system ensures unadulterated bathing pleasure with minimal cleaning effort. The 3D filter technology in every Whirlcare® with the Whirlclear pre-filter and the two main filters automatically removes dirt particles and impurities caused by insects, leaves, foliage or pollen from the water surface. Our advanced filter technology not only ensures efficient surface cleaning, but also performs the important function of water absorption. The water is sucked in via the skimmer, through the pre-filter, then through the main filters and directed to the UVZONATOR, where it undergoes thorough disinfection.

### Multi-stage filter and water purification system

Hygienically perfect water disinfection.  
A good feeling



The UVZONATOR® in conjunction with Whirlclear - pure water is an essential component of the Whirlcare energy-safing management-system





# Smart premium water filter

The ingenious water filter combination of pre-filter and main filter

## PERFECT WATER QUALITY

Filters up to 1 Micron



- Crystal clear water quality
- Less chemicals - more health
- Ease to clean & durable
- Protection against biofouling & germination
- Ultralight & efficient
- Quick to clean

Our innovative Whirlclear whirlpool and swim spa water filters can be easily and individually adapted for almost all whirlpool manufacturers and whirlpool models and filter housings. The Whirlclear pre-filters can be inserted into existing basket filters or simply into the skimmer box above the main filters. They can be easily and quickly cut to size for each filter housing using scissors. Whirlclear can be used immediately in any filter housing / skimmer without conversion or further aids. The insert is easy, quick and absolutely clean. The main filters can also be used in other filter housings or containers. This allows you to replace almost all lamella filters and/or filter cartridges. Whirlclear filters are free from plastics and paints, toxins, silver ions, CFCs, PCBs, formaldehyde and toxic substances. Whirlclear is UV-resistant, flame-retardant, resistant to cleaning and protected against fungal, insect and mold infestation. Due to its high density, Whirlclear filters solid contaminants down to the nano range. It filters 99.5% of organic and inorganic particles with a size of 30 µm and even down to less than 1/1000 mm (1 µm). Whirlclear is recyclable and easy to dispose of with household waste. The premium filter reduces biofouling, has a long service life and is easy to rinse out under flushing water. It is suitable for vertical and horizontal filtration with maximum flow, without resistance. Whirlclear reduces energy, water, operating costs and time expenditure and also reduces the need for disinfectants or water preservatives such as chlorine by up to 60% compared to conventional lamella or cartridge filters. Simply rinse the Whirlclear filters with clear water and then remove bacteria and fungi with hot water at approx. 70° C for approx. 3 minutes without chemicals.

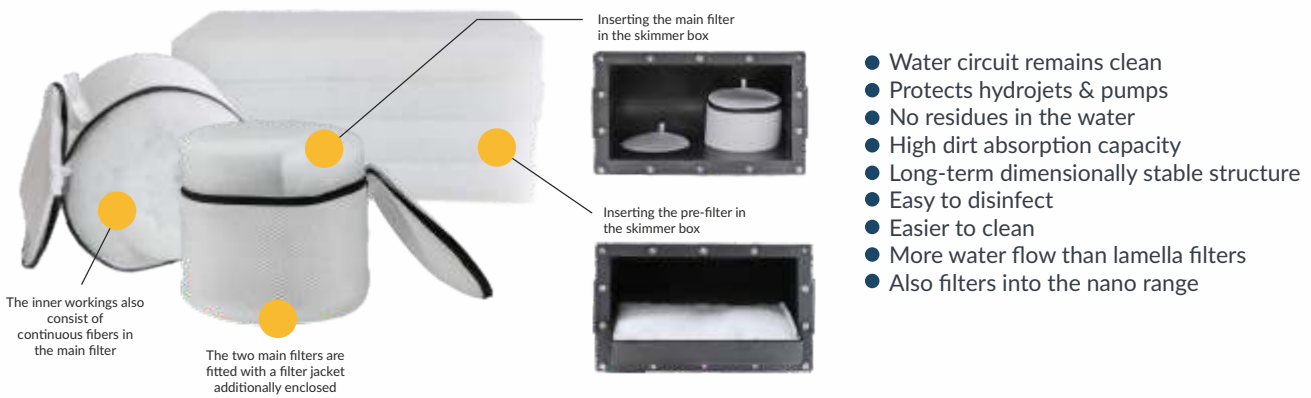

# The Whirlcare® insulation

High-performance insulation. Easy access to the installation level  
**Better to insulate thinly than poorly thickly**

## RUNDUM GESCHÜTZT



$$U = 1/RT = 0,32 \text{ W/m}^2\text{K}$$

Our hot tubs set new standards in terms of insulation technology and ensure that you can enjoy the cozy warmth to the full. Thanks to our innovative Isogreen insulation, the external insulation between the base tub, the whirlpool tub body and the steel frame is seamless and tight. The form-fitting and coherent insulation prevents unnecessary cold bridges, so that your hot tub is insulated almost airtight. You can concentrate fully on your relaxation without valuable heat escaping. The secret of our Isogreen insulation lies in the graphite particles it contains. These reflect the infrared heat radiation from the technology, pumps and whirlpool tub back into the interior of the whirlpool. As a result, the pleasant warmth is retained and you can relax in a whirlpool at the perfect temperature. Whirlcare® is proud to be the only manufacturer to have the U-value / K-value of the 4 cm thick Isogreen special insulation, as only the U-value is meaningful for the insulation value. With a U-value of 0.32 W/m²K, our Isogreen insulation offers outstanding heat transfer performance. In comparison, the same insulation value would require 13 cm thick polystyrene insulation / EPS, XPS or Styrodur insulation with additional aluminum foil. However, this space is not available in most whirlpools with the appropriate technology. With Whirlcare hot tubs, you can rest assured that we use the best possible insulation technology to optimize energy consumption and minimize environmental impact.



### Isogreen 40 mm

#### Wärmedurchgangskoeffizient

$$U = 1/RT = 0,32 \text{ W/m}^2\text{K}$$



Styropor 50 mm  
 Heat transfer coefficient  
 $U = 1/RT = 0,70 \text{ W/m}^2\text{K}$



Insulating wool 60mm  
 Heat transfer coefficient  
 $U = 1/RT = 0,60 \text{ W/m}^2\text{K}$



Wood paneling 22cm  
 Heat transfer coefficient  
 $U = 1/RT = 0,53 \text{ W/m}^2\text{K}$



Vertically perforated brick 55cm  
 Heat transfer coefficient  
 $U = 1/RT = 0,54 \text{ W/m}^2\text{K}$



Even the top and bottom edges of the whirlpools and the steel frames are insulated with our edge protectors with ISOGREEN material, so that no cold bridges can occur even at the protrusion points.

## Hot tub floor insulation



Every single component is carefully thought through to ensure maximum energy efficiency. That's why we have also thought about the insulation of the base tray. With our innovative Isogreen technology, we also insulate the gap between the base tray and the assembly level. However, this insulation is even more reinforced and keeps insects and rodents out, and we understand that optimum insulation does not allow any gaps. Even if this area is not directly visible from the outside, many manufacturers neglect or overlook this important insulation measure. But not with Whirlcare®! We pay attention to every detail to prevent additional heat loss.

# The Whirlcare® climate chamber tests

Transparency creates trust

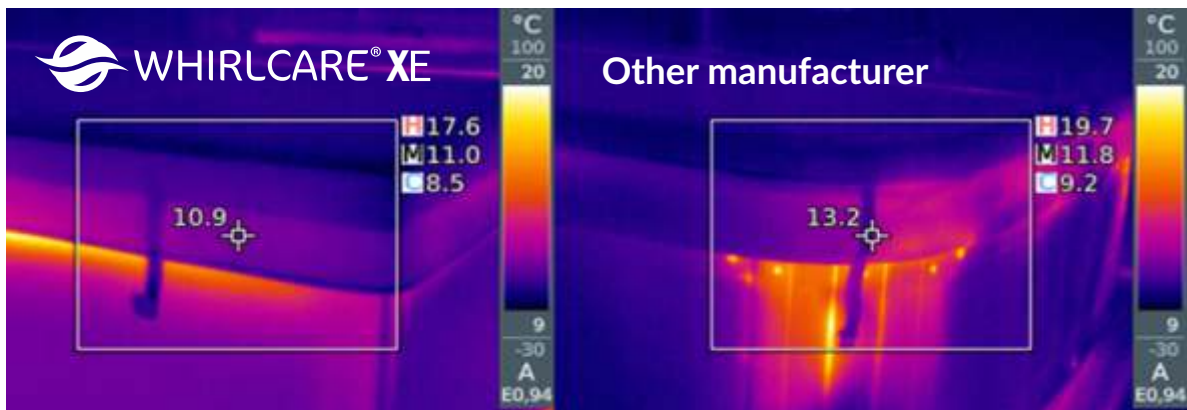

WCI Research & Development conducts real tests in the company's own climate chamber. This is 15 meters long, 4 meters wide and 3 meters high. Enough space to carry out countless whirlpool measurements. The tests are carried out under realistic climatic conditions, cold and humidity. For example Stuttgart: annual average of 83.92 % humidity at 9.76° C. We test under identical climatic conditions, e.g. energy efficiency, external influences, UV radiation and sound emissions. Our aim is to change the market in the long term, e.g. by introducing an energy label like the one for refrigerators.

**Ø Verbrauch p.a.**

Other manufacturers	6.000 kW
Whirlcare®	1.200 kW
<b>Savings p.a.</b>	<b>4.800 kW</b>

Per month = 400 kW x 0,3 €\* = 120 €  
 Per year = 120 € x 12 = 1.440 € x 20 years

**Savings over 20 years = 28.800 €**

\*Ø electricity price per kWh € 0.30



## What few people know

Do not rely on marketing claims such as Scandinavian, Nordic or Polar insulation. The only measurable and comparable value, as with buildings, is the U/K value. Forget advertising claims in Germany or Europe according to the ANSI/APSP/ICC 14- 2019 energy consumption data from California. The measurements there are based on an average outside temperature of 17.2°C with a water temperature of 37.7°C. The data only refers to stand-by operation. Taking into account realistic conditions of use in Germany, the actual consumption is approx. 100% higher than stated.

According to the above-mentioned energy consumption data from California ANSI/ASP/ICC 14-2019, all

**Whirlcare® hot tubs require less than 1,9 kW/Day**

# The Whirlcare® Protective Panels

Exterior paneling as an eye-catcher in the garden



Immerse yourself in timeless elegance and long-lasting quality. Our exterior cladding is made with innovative Protective Panels, which not only have excellent and exceptional torsional rigidity, but are also UV-resistant. We are so confident in the quality of our exterior cladding that we offer you an impressive 10-year guarantee on lightfastness. This means that even after a decade, the modern and sophisticated design of your hot tub will look almost as radiant as the day it was delivered. No fading, no visual impairment - just lasting beauty and aesthetics. In addition to durability and aesthetics, we also attach great importance to sustainability. The Protective Panels are made from 100% recyclable materials, so you not only have a whirlpool of the highest quality, but also make a contribution to the environment. Enjoy your wellness oasis with a clear conscience and the certainty that you have opted for an environmentally friendly solution. Discover perfection in design, durability and environmental friendliness.



## Installation at ground level

Built-In variant (floor-mounted and/or partially recessed)

All models are available in the "BUILT-IN" version (sunk into the floor or at ground level). Here, OSB panels are fitted to protect the interior instead of the protective panels. Simply screwed together. Without magnetic holders and without stainless steel corner bracket rails.



# The Whirlcare® Protective Coats

High resistant thermal cover



A good thermal cover is the easiest way to keep the heat in the Whirlcare® and save energy. It also prevents soiling from leaves or insects, which is particularly important if the Whirlcare® is unprotected in the garden. For us, it is therefore simply part of the package and is supplied as standard with the purchase of a Whirlcare®. The Whirlcare® Protective Coat is extremely hard-wearing thanks to its special au au and the materials used, and is so safe and stable that you could even walk on it. At the same time, it scores with better insulation values than conventional covers. This is partly due to the innovative ISOGREEN high-performance insulation, which we also use for the external insulation of our Whirlcare® whirlpools. The insulation is much more efficient than polystyrene or any other insulating material and is also fully recyclable. On the inside and underside of the Whirlcare® Protective Coat, we have incorporated a special mesh-like fabric with a special structure that wicks away water vapor and condensation and allows it to drip off. As a result, no moisture can accumulate, which prevents mold growth and significantly extends the service life of the cover.



Whirlcare® Protective Coat Standard in 4 Colors

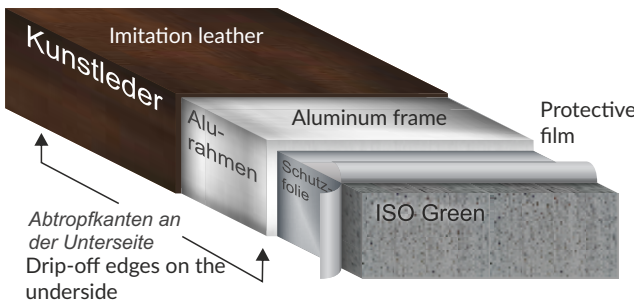

For an optimal and effective finish to our Protective Covers, it is crucial that the bath rim forms a continuous and tight seal all around, up to 5 cm wide, without any indentations or recesses for control panels or cup holders. Our Protective Covers are designed to fit the edge of the bath perfectly and have no gaps or weak points.



If the hot tub is in use and you have to shovel before you can relax, then your complete hot tub insulation is perfect



**WHIRLCARE®**  
WHIRLPOLS & SWIM-SPAS  
MADE IN GERMANY

**Ø-energy consumption per year**

Category	Energy Consumption (kWh p.a.)
Competition	6,000
Whirlcare	1,195

**-80%**

**99,55 kWh / 1.195 kWh**  
per month / per year

**1h** Usage **38°C** **8,2°C**

**1,422 L** **7,6 kW**

**XE System 2023**

ISO GREEN: U = 1,81 + 0,32 W/m²K

Energy saving with the Whirlcare energy saving system

Feature	Energy Saving (%)
VARIOUS Hotrot	40%
SmartSpa Control	20%
ISO GREEN Isolation	25%
Protective Coat	25%
HeatEnergy Pump	60%

## High Quality in Technology The hot tub of a new generation

XE Exchange Efficiency  
The Whirlcare® energy-saving management-system

# Whirlcare® XE-Technology

The new generation of hot tubs & swim-spas

XE stands for Exchange Efficiency

However, the multitude of literal translations always comes down to the same denominator. For the new generation of hot tubs & swim spas - Made in Germany, we have transformed performance. The challenge was to rapidly reduce energy costs while improving the massage effect and health care. We have more than succeeded. With the Whirlcare® XE models, you save up to 80% energy compared to conventional whirlpools, with more performance, sustainable health care and a better massage effect.

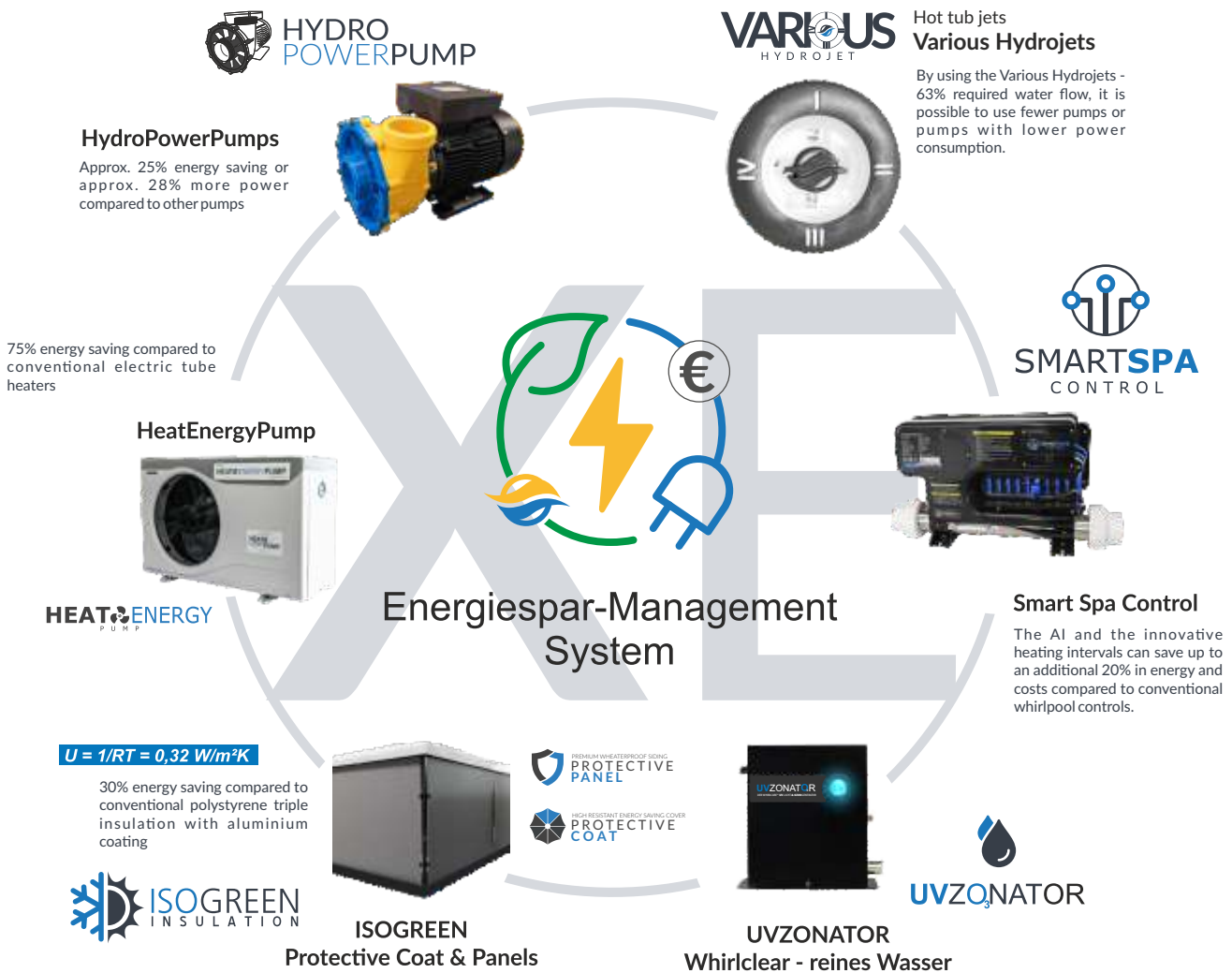

Each individual measure is a major step forward in itself and saves a percentage of energy compared to conventionally used components. However, only with the Whirlcare energy management and system as a whole can the maximum energy saving of up to 80% be achieved compared to other whirlpool and swim spa providers, even in the cold regions of Europe.

# QUALITY

# Die Whirlcare® Warranty periods

Spare parts guarantee

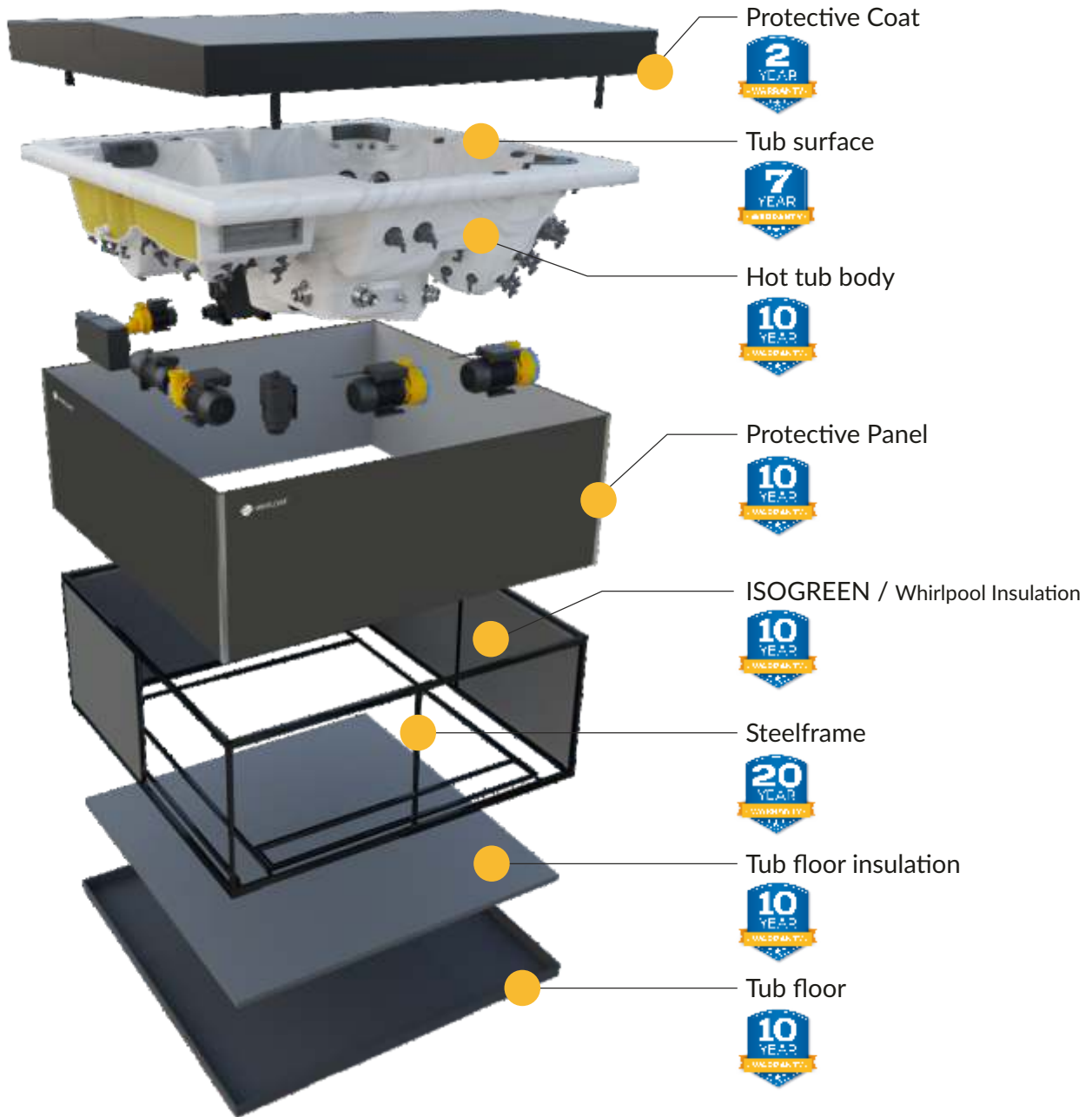

## A comparison, which is really worthwhile

Our warranty periods are very different from those of conventional whirlpool or swim spa manufacturers. A comparison is worthwhile here, because we have not only focused on durability, but also on resource-saving, sustainable production and durable materials that are free from harmful substances and recyclable. We offer a 10-year spare parts replacement guarantee and a 5-year guarantee on the piping system. All other electrical components are covered by a 2-year warranty.



Spare parts replacement guarantee

10 years

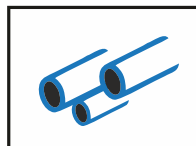

Piping system  
5 years

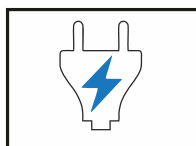

All other electrical parts  
2 years



# Construction & Equipment



We are so convinced of the quality of our hot tubs in the XE models, that we have

## Warranty & Guarantee

for the first 2 years as a manufacturer with the end costumers ourselves

XE

A whirlpool is without question a jewel in your garden or on the terrace. But it is the inner values that decide whether you will enjoy it for a long time or have to worry about repairs and exorbitant energy costs. A Whirlcare® not only has a modern design. We only use durable, pollutant-free and energy-efficient materials that are kind to the environment and your wallet. This starts with the highly stable, KTL-coated steel frame and extends to the Protective Panel, our high-quality, fully recyclable outer cladding. In between, there are plenty of innovations.

## The Whirlcare® ABS Tub floor



The ideal material for the stable base tray is recyclable ABS material. Why is this so special? Quite simply, this design protects your hot tub from unwanted guests such as rodents and insects. No more worries about pesky visitors disturbing your relaxing moments or damaging your technology. The solid base tray reliably keeps them out and ensures that you can enjoy your privacy without any restrictions.

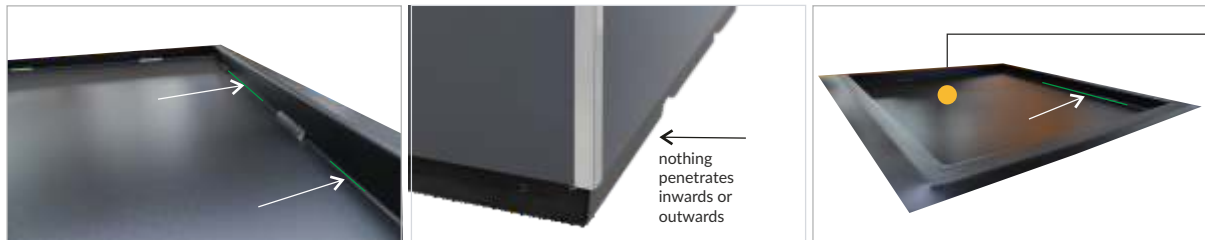

But that's not all. Our ABS floor pan offers another advantage: it also protects your hot tub from moisture. Moisture can cause unwanted damage in the long term, but with our innovative design you don't have to worry about that. You can concentrate fully on the pleasant warmth and the unique Various hydromassage, while the floor tray ensures that your hot tub remains in top condition. The special ISOGREEN insulation of our floor tub is a masterpiece of engineering. It forms a completely sealed and tight-fitting barrier between the KTL-coated steel frame and the inside of the hot tub. This prevents cold from the floor penetrating into the hot tub or the precious heat from the hot tub escaping to the outside.

ISOGREEN tub floor insulation is also used

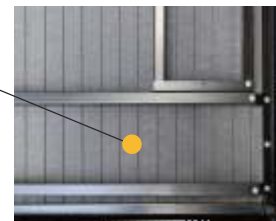

## The Whirlcare® Steel frame



Experience the exceptional stability and durability of whirlpools from Whirlcare. Our whirlpool frames are not only robust and functional, but also optimally protected against corrosion. The core of our hot tub frames consists of an impressive 2 mm thick KTL-coated steel frame. This innovative coating technology ensures long-term protection against corrosion and gives the frame exceptional durability. No matter what weather conditions or environmental influences affect your hot tub - our steel frame remains reliable and resistant. The steel frame has been designed not only for stability and durability, but also for flexibility and functionality. It is designed to adapt perfectly to the requirements of your hot tub. Thanks to the static calculation, you can be sure that the frame will retain its stability even during intensive use. To ensure a firm connection between the steel frame, the whirlpool tub and the base tub, we use special recyclable ABS brackets. These brackets not only ensure a solid connection, but also easy maintenance and repair.



## The Whirlcare<sup>®</sup> tub body

In the sustainable Bio-Lok Microbe Shield process



# SANITARY ACRYL 4,75mm



The surface of our whirlpool tub is made of sanitary acrylic with an antibacterial Microban surface treatment. This innovative treatment ensures that microorganisms cannot adhere and provides you with a hygienic environment. Thanks to the cross-linked molecular structure, the material is also more resistant to UV radiation, chemicals and stains. So you can concentrate fully on your bathing pleasure without having to worry about cleaning or possible damage. Our surface material is equipped with a Bio-Lok microbial shield that naturally inhibits the growth of microorganisms. This means you don't have to worry about bacteria or unwanted germs. Enjoy your bath in a whirlpool that offers you the highest level of hygiene and safety. At Whirlcare, we focus on quality and durability.

**50% stronger material than our competitors**  
**50 % more quality**



We only use 4.75 mm thick sanitary acrylic material for our whirlpool tubs, as opposed to the 3.2 mm that is usually used. This means that our tubs contain 50% more material and therefore have 50% higher manufacturing costs. But this investment pays off, because you get 50% more quality and stability. Our hot tubs are designed to provide you with long-term enjoyment and reliability. The use of 50% more material ensures outstanding surface quality even in otherwise critical areas that occur when deep-drawing a hot tub. No thin spots or signs of instability - instead you get a whirlpool tub that is both visually appealing and durable.

# The Whirlcare® tub reinforcement Sustainable - for statics & insulation



## This is about more than just tub reinforcement

Many manufacturers use glass fiber reinforced plastic (GRP) to reinforce whirlpool tubs. The vapors and dust produced during GRP processing pose a health risk to people and can damage the production facilities or the plastic parts themselves. Recycling is also problematic: once hardened, GRP cannot be melted down again and broken down into its components. As a material, GRP is classified as recycling class seven, which means that it cannot be reused. We do not want to impose this on the environment or our employees. Whirlcare® uses an innovative, energy-efficient polyurethane-based multi-component reaction system for the tub reinforcement, which is biodegradable, environmentally friendly and recyclable. The PU material does not contain any plasticizers or solvents. Both the material and the spraying process using state-of-the-art robots allow faster, environmentally friendly and customized production of your desired Whirlcare®. In addition, the special PU material provides good insulation and therefore keeps the water in the hot tub warmer for longer.



## For the environment & our employees

Our robotic technology enables precise and consistently high quality in the processing and application of the polyurethane to the back of the tub. Each spa is manufactured with care and precision to provide you with a product of the highest quality. Whirlcare® hot tubs are not only a symbol of luxury and relaxation, but also of environmental awareness. Our PU coating helps to minimize energy consumption and reduce the ecological footprint. Our employees do not have to wear full body suits, handle hazardous materials and apply or spray toxic substances with a breathing mask.





*Time*  
that we take for ourselves,  
is time that gives us something

# DESIGN



## Timeless. For modern demands The *Bauhaus* style

At Whirlcare®, we combine DESIGN and FUNCTION to perfection. Inspired by the Bauhaus style, one of the most influential design movements of the last century, we have created an aesthetic vision that is still timeless and fascinating today. The renowned architect and designer Walter Gropius, one of the most brilliant minds of his time, inadvertently served as the inspiration for our modern, minimalist and functional design. The clear lines, angular shapes and subtle colors are characteristic of the Bauhaus style and have had a lasting influence on modern design. As a pioneer among whirlpool manufacturers, Whirlcare® was the first in the world to perfect the Bauhaus style and integrate it into our whirlpools - without visible screws. Our angular shapes and straight lines combine timeless elegance with modern aesthetics. They fit in perfectly with contemporary architectural concepts and make a statement in any room. Our whirlpools are not only luxurious wellness oases, but also design objects that embody the spirit of the Bauhaus style. They are an expression of timeless beauty and clear shapes that blend harmoniously into any environment.

Whether in private residences, exclusive hotels or modern new builds, Whirlcare® whirlpools set a new standard with their Bauhaus-inspired design. They combine functionality with aesthetics and create an atmosphere of luxury and well-being. Experience the combination of design and function with Whirlcare. Immerse yourself in a world of elegance, clear lines and timeless design. Be inspired by our whirlpools and bring modern flair into your home. Whirlcare® - perfection in Bauhaus style. A combination of timeless design and innovative technology without visible screws for today's discerning people.

# 7 Die 7 Whirlcare®

*Aesthetics* Whirlcare® Design & function in perfection



## The Bauhaus style

Whirlcare® Industries has succeeded in combining maximum functionality with a modern and timeless design that impresses with its elegance and striking design language. The elegant, angular tub shape combined with the ergonomically and anatomically shaped massage seats and loungers creates exciting accents. While the majority of all whirlpools are rounded, the Whirlcare impresses with its Bauhaus-style corners and edges on the outer line.



## Curved lines & ergonomics

Straightforward on the outside and ergonomic on the inside. This is how the whirlpool massage seats and loungers are designed. The jets are arranged in such a way that they can develop their effect precisely at the muscular reaction points of the body. The curved design lines ensure that you can let yourself glide completely into the whirlpool massage seat or lounger.



## The corner rails & external paneling

A Whirlcare® is unmistakable thanks to its individual outer cladding with lightfastness, durability and high-quality design. The magnetic stainless steel corner rails complete the harmonious and stylish design. The screwless one-man revision with access to the installation level can be achieved without tools.



## Optics of the displays

Care has been taken to ensure that the control panels fit into the overall appearance of the Whirlcare® whirlpool. The control panels have a so-called resistive touchscreen. It recognizes physical pressure through built-in sensors. Unlike the digital touchscreen, drops of water or moisture do not restrict its functionality.



## Corporate Design of the hot tub components

Jets, diverters, neck cushions and skimmers are designed in the modern Whirlcare® highlight color anthracite and thus follow the corporate design of the whirlpools & swim spas Made in Germany. Here too, ease of use is the top priority, coupled with integration into the overall design.



## Design integration of the whirlcare senses

All operating and functional elements are embedded in the unmistakable Whirlcare® style and strengthen the design in terms of function and operation. All heads are equipped with the Whirlcare® logo and are also backlit from the First Class version upwards.



## Protective Coat thermal cover

Finally, of course, our Protective Coat thermal cover, which, like all our components, is also available in Whirlcare® anthracite and attracts attention in the garden, even when the hot tub is not in use. This timeless design blends seamlessly into almost all garden and outdoor environments.

# Three equipment variants

Premium • First Class • Luxury

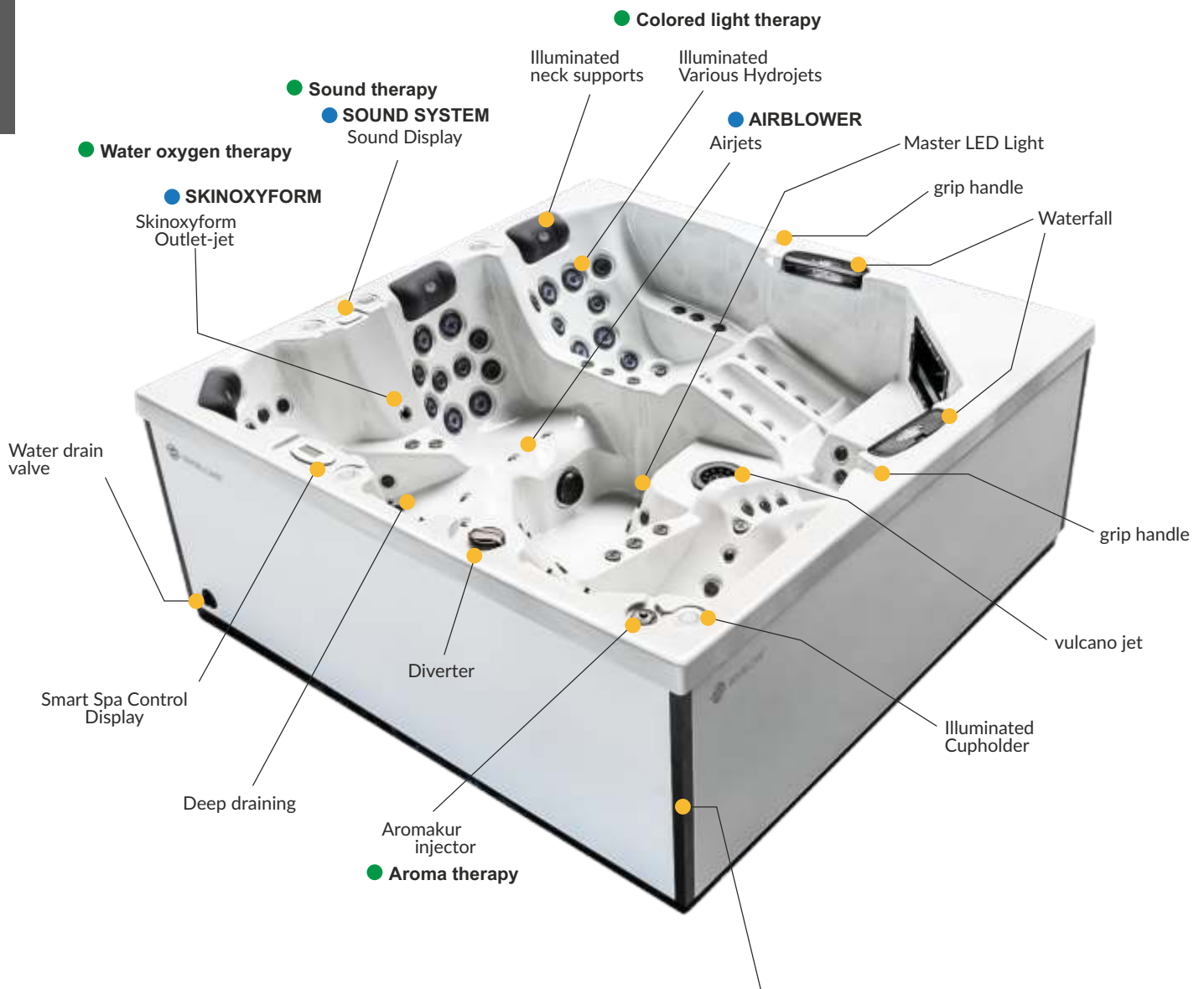

## Stainless steel corner bracket

At Whirlcare, we attach great importance to ease of use and high quality. That is why we have equipped the side closure of our whirlpools with innovative magnetic technology. Instead of laboriously loosening or fastening screws, we use high-quality, rust-proof magnetic stainless steel corner rails to close off the whirlpool sides. The side trim is effortlessly fixed in place by the magnetic connection without the need for tools. You can remove or reattach the side panel quickly and easily.

This easy handling allows you to carry out maintenance or access important components without any great effort. The use of magnetic stainless steel corner rails not only ensures quick disassembly, but also secure and stable attachment. There's no need to worry about rust or corrosion - our high-quality materials are designed to last and give you long-term enjoyment of your hot tub. With Whirlcare® you can rely on a user-friendly and reliable solution - without screws and the use of tools or that the side panel can only be removed by 2 men. The magnetic technology enables smooth handling, saves you valuable time and effort and reduces service costs in the long term.



## Sound system SOUND THERAPY

Hot tub sound on a new level - easy to operate



With our practical control panel on the hot tub, the Bluetooth/WiFi connection via the mobile app and the Smart Control System, you have full control over your sound experience. Thanks to the integration of online music streaming services such as Spotify, you can play your favorite music directly through the sound system. Discover a new dimension of acoustic pleasure with our innovative Whirlpool sound system! The high-quality Exciter structure-borne sound loudspeakers used especially for the XE generation, which are discreetly positioned under the edge of the bath, transmit music across the entire bath body. Immerse yourself in a world of sound while you relax in your hot tub. But that's not all - our sound system is supported by a powerful amplifier with subwoofer in the lower part of the whirlpool interior. Enjoy impressive sound quality with a rich bass that gives you an intense acoustic experience.

## Aromakur Injector AROMA THERAPY

Hot tub fragrance experience at the touch of a button



Would you like to add a special fragrance to your wellness walk? With our aroma treatment injector, you don't even have to get up. (Provided you have already filled up your aroma chamber before your wellness session). Using the injector, you can easily fill your essential aroma fragrance oil into the aroma chamber and close it again. The push button on the top of the injector serves as a feed sequence. When you press the button, the scented oil flows evenly into the whirlpool water and is distributed. Now switch on the Airblower and the fragrance/water molecules burst on the surface of the water, distributing the aroma over the surface of the water. Now you can enjoy your own personal aromatherapy.

## Whirlpool Lighting COLORED LIGHT THERAPY

LED's, Master-Light, backlit highlights components



Enjoy a customizable color spectrum with the large master light that allows for therapeutic coloring. Experience the ultimate in comfort with illuminated neck cushions, illuminated cup holders and illuminated jets. Every detail has been carefully considered to give you an unparalleled spa experience. Our VARIOUS™ hydrojet jets, which are also illuminated, are a particular highlight. They become an eye-catcher and enhance the effect of the colored light therapy. This gives your hot tub a luxurious appearance that will delight you. And the best thing about it: you can control the colored indirect lighting conveniently on the control panel or via our practical app.

# Skinoxyform® / Der O<sub>2</sub> Fountain of youth

Skinoxyform-pump & Outlet jet

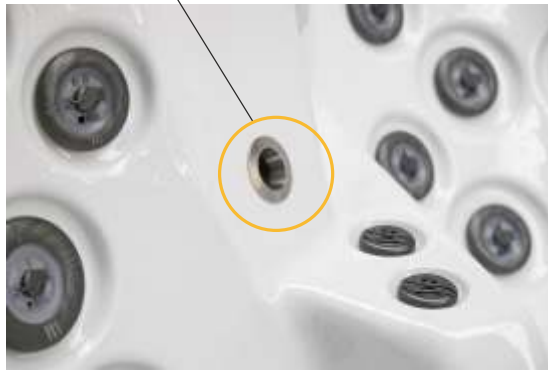

Discover the revolutionary Skinoxyform oxygen therapy and treat your skin to pure luxury and natural beauty. With this unique treatment, your Whirlcare whirlpool becomes your personal fountain of youth for radiant skin and a youthful appearance. Thanks to a special, high-compression membrane pump, the natural source of oxygen - the air around us - is introduced into the whirlpool water. The oxygen molecules combine with the water and form fine bubbles that gently hit your skin during use. These tiny water oxygen bubbles penetrate the uppermost layers of the skin before bursting and releasing their beneficial effects. Skinoxyform oxygen therapy offers you a wide range of benefits. On the one hand, it stimulates the production of serotonin, the so-called "happiness hormone", and contributes to your general well-being. At the same time, it provides your skin with intensive moisture, reducing dryness and feelings of tightness. The Skinoxyform application also has positive effects on the appearance of your skin. Fine lines and wrinkles can be reduced, while blemishes and imperfections are diminished. Your skin will look brighter, smoother and more youthful. Experience the unique Skinoxyform oxygen therapy and transform your Whirlcare whirlpool into your personal skin care oasis. Immerse yourself in the refreshing and revitalizing water and feel how your skin glows from the inside out and feels great even without moisturizer.

*Looking*

young has nothing to do with your age

(Skinoxyform® Philosophie)



# Airblower with heating

Additional air movement via the airjets



## RELAX - SYSTEM



Our advanced variable **Airblower - Made in Germany** -built-in heater is the perfect addition to your whirlpool experience. The Airblower's built-in heater heats the air drawn in, which means that the whirlpool water is no longer cooled by the cold outside air. This means you can enjoy the warm water to the full without any unpleasant temperature differences. The variable air blower also offers you a gentle and adjustable air massage. You can set the intensity of the air massage according to your personal preferences and let yourself be pampered by the pleasant air bubbles. Relax and feel how the gentle air massage loosens your muscles and revitalizes your body. Our air blower with heater is mounted on a separate mounting plate to ensure optimum performance and safety. You can rely on our Airblower to work reliably and efficiently so that you can concentrate fully on your relaxation. Another advantage of the Whirlcare® Airblower is its impressive noise reduction. At just 39 decibels, it is one of the quietest air blowers on the market. Enjoy your whirlpool moments in a quiet and relaxed atmosphere without being disturbed by annoying noises. Whirlcare® sets new standards in comfort and quality. Experience the difference that our variable air blower with built-in heating makes and enjoy a whirlpool experience in a class of its own.

### Noise reduction, mounting plates & supports

Stable & durable - Against vibrations and noise

Experience pure relaxation without disturbing noises - with Whirlcare whirlpools from the XE model range. Because we know that the supply of air for the jets, pumps that are not installed with vibration damping or incomplete insulation can lead to annoying noise levels of over 60 dB during operation. This noise not only disturbs you, but possibly also your neighbors. At Whirlcare, we have done everything we can to prevent unwanted noise so that you can enjoy your hot tub in peace. The bursting of air bubbles on the water surface and the frequency sounds of the pumps during water circulation can be very disturbing.



Through careful design and high-quality materials, we minimize disruptive noise to an absolute minimum. Our XE models have the quietest operating noises in the world - as confirmed by decibel volume measurements. We rely on an innovative and stable installation solution to offer you a carefree and maintenance-friendly whirlpool experience. All essential components, from the control unit and HydroPowerPumps to the air blower and subwoofer, are mounted on special mounting plates with a high-quality cathodic dip coating. These mounting plates are part of an additional mounting frame, which in turn is firmly attached to the outer frame. The result? An extremely stable and durable fastening of the components. Thanks to this innovative design, you benefit from a number of advantages. Firstly, the stable assembly guarantees a long service life for the components. You can rest assured that your Whirlcare whirlpool components will continue to function reliably and give you pleasure even after many years. In addition, the careful assembly allows for uncomplicated maintenance and replacement of individual components. If a component needs to be serviced or replaced, this can be carried out without a great deal of effort. The components are easily accessible and can be replaced without any problems so that you can enjoy your hot tub again quickly.

# Extended Highlights

All comfort components with a uniform appearance



## 1 Vulcano jet Abdominal & chest massage

The Whirlcare® models not only feature our unique Various Hydrojets, but depending on the model also a large jet that develops its effect above the surface of the water. The volcano jet. It is a large bubble jet that is positioned in the middle of a Whirlcare®. This allows you to massage those parts of your body that are generally not reached in conventional whirlpool models. By bending over the Vulkanjet, for example, it reaches the chest and stomach.



## 2 Waterfall Beruhigung für das Auge & das Ohr

Experience the soothing sound and aesthetic beauty of the illuminated Whirlcare® waterfall. Our innovative design allows you to directly regulate the strength of the waterfall without the need for additional controls. According to your preferences and needs, you can adjust the intensity of the waterfall and create an atmosphere of relaxation. Our waterfall is not only an aesthetic highlight, but also functional. Even when the whirlpool is not in use, the waterfall can remain switched on during circulation. This supports efficient water circulation and prevents stagnant water. Enjoy a clean and hygienic hot tub that is always ready to offer you a refreshing and relaxing experience and visual highlight.



### 3 Head- / neck rests For more comfort

Our hot tubs are equipped with head/neck rests on all seats and loungers to offer you maximum comfort. Sit back, relax and leave the stress of everyday life behind you. Our inlays with the Whirlcare logo are not only elegant details, but also beautifully illuminated. They create a pleasant atmosphere and bathe your whirlpool in a gentle play of light that invites you to relax and dream. Enjoy the luxurious combination of comfort and aesthetics. Our head/neck rests provide optimum support and relief for your neck muscles, while the illuminated inlays create a unique atmosphere.



### 4 Control Panel Display Absolute user-friendly

With us, you won't find complicated touch displays, but an intuitive and user-friendly control panel that works smoothly even with wet fingers. With our innovative control panel, you don't have to worry about water damage or unreliable operation. Whether you are just getting out of the hot tub and have wet fingers or want to change the settings while relaxing in the bath - our control panel is always reliably at your disposal. Enjoy the freedom and convenience of controlling your hot tub effortlessly without compromising on quality. Whirlcare® offers you a modern and user-friendly control solution designed for your needs. We have gel-filled our control panel to make it moisture resistant and extremely durable.



### 5 Diverter / Flow regulator Handle comfort

With the Whirlcare® hot tub diverter, you can choose the water flow between the volcano jet and the massage jets. The diverter is perfectly controllable for the thumb and ring finger thanks to its curved shape. With its circular feel, we have even thought of the details. Our diverter is designed in the shape of the Whirlcare® logo to allow you to operate it comfortably even with wet hands. This means you can easily switch the water flow to the Vulkanjet or the Various Hydrojets at any time and customize the massage experience to suit your preferences.



### 6 Cupholder For illuminated glasses (Drinks)

Enjoy your whirlpool to the full with our innovative design! Our cup holders on the edge of the bath provide the perfect place to put your drinking glasses. They are practical and provide maximum comfort. As a special highlight, all cup holders in the XE models are naturally illuminated.



### 7 Grip handle / indentation Exit aid

We know how important it is to get up and out of the massage table comfortably and have therefore developed a special grab rail for you. In our intelligent design, we have created a practical recess in the edge of the bath to give you extra support. Our grab rail provides a feeling of safety and makes it easier for you to get in and out of the hot tub - even when lying ergonomically low.

### 8 Water drain valve Easy draining

Every Whirlcare hot tub has a central water drain that makes draining the water effortless. No more fiddling around with various tools or complicated draining processes. All you have to do is connect a hose to the outlet valve - with our practical quick-release fastener, this is done in no time at all. The central water drain is designed to reach and empty all the main ergonomically deep seats and loungers of the spa in the XE models with deep draining and Airblower. This means that the entire water is drained almost completely. This makes changing the water child's play.

 **WHIRLPOOLS & SWIM-SPAS**  
**MADE IN GERMANY**





**XE models  
of the new generation**

MASTER  
ATTRACTION  
PERFECTION  
EXCELLENCE  
MAGIC  
TEAMPLAYER



**XE-S models  
of the new generation**

RELEASE  
ARTWORK  
IMPRESSION  
IDENTITY

**New generation  
swim spa models**

WELLPOWER  
FAMILY  
SURFER

# WASTEF





# MASTER XE

The Hot tub for the highest demands









	Premium	First Class	Luxury
<b>MASTER DATA</b>			
Measurements	234 x 234 x 94 cm	234 x 234 x 94 cm	234 x 234 x 94 cm
Seats	3	3	3
Loungers	2	2	2
Water volume	1335 L	1335 L	1335 L
Net weight	~402 kg	~412 kg	~430 kg
Power supply	400 V / 27,25 A	400 V / 29,25 A	400 V / 30 A

	Premium	First Class	Luxury
<b>JETS</b>			
VARIOUS HYDROJETS (2"/3"/4")	122 (72/28/22)	122 (72/28/22)	122 (72/28/22)
Airjets	-	20	20
Volcano jet	1	1	1
<b>Total</b>	<b>123</b>	<b>143</b>	<b>143</b>

	Premium	First Class	Luxury
<b>PERFORMANCE</b>			
HydroPowerPump	2x 2,6 kW	2x 2,6 kW	2x 2,6 kW
Circulation pump	200 Watt	200 Watt	200 Watt
Electric heater	5,5 kW	5,5 kW	5,5 kW
Airblower with heater	-	750 Watt	750 Watt
Bypass for heat pump connection	yes	yes	yes
SKINOXYFORM (oxygen therapy)	-	-	1,65 kW
UVZONATOR (disinfection)	yes	yes	yes
<b>Peak load</b>	<b>10,9 kW</b>	<b>11,7 kW</b>	<b>12 kW</b>

	Premium	First Class	Luxury
<b>CONTROL</b>			
Smart Spa Control	yes	yes	yes
Display	SSC.XE	SSC.XE	SSC.XE
WiFi	yes	yes	yes
Remote maintenance	yes	yes	yes
App control	yes	yes	yes
Voice control/Google/Alexa	-	-	yes

	Premium	First Class	Luxury
<b>COMFORT HIGHLIGHTS</b>			
Soundsystem: 4x Exciter 50W, 1x Subwoofer 100W	-	-	yes
Aromatherapy	-	yes	yes
Master LED	1	1	1
LED lighting/colour light therapy	22	228	228
Waterfall illuminated	2	2	2

	Premium	First Class	Luxury
<b>MORE INFORMATION</b>			
Neck support illuminated	5	5	5
cup holder illuminated	5	5	5
Tub draining	Standard	Deep draining	Deep draining

Premium

  
VARIOUS Jets

  
Volcano jet

  
Bypass

  
Waterfall

  
UVZONATOR

  
LED

  
WiFi App control

  
cup holder

First Class

  
Airblower with airjets

  
Aromatherapy

  
deep draining

  
colour light therapy

Luxury

  
Soundsystem

  
Voice- & remote control

  
Skinoxyform

Protective Panel Standard  
Outer panelling



Protective Coat Standard  
Thermo cover



Thermal covers in black, brown and grey are not available for all models.  
Please check availability in advance. The Whirlcare® main standard colour is anthracite

# ATTRACTION



# ATTRACTION XE

An attraction for wellness enthusiasts









	Premium	First Class	Luxury
<b>MASTER DATA</b>			
Measurements	215 x 190 x 88 cm	215 x 190 x 88 cm	215 x 190 x 88 cm
Seats	1	1	1
Loungers	2	2	2
Water volume	730 L	730 L	730 L
Net weight	~355 kg	~365 kg	~385 kg
Power supply	400 V / 25,25 A	400 V / 27,15 A	400 V / 27,85 A

<b>JETS</b>			
VARIOUS HYDROJETS (2"/3"/4")	90 (64/14/12)	90 (64/14/12)	90 (64/14/12)
Airjets	-	13	13
<b>Total</b>	<b>90</b>	<b>103</b>	<b>103</b>







<b>PERFORMANCE</b>			
HydroPowerPump	2x 2,2 kW	2x 2,2 kW	2x 2,2 kW
Circulation pump	200 Watt	200 Watt	200 Watt
Electric heating	5,5 kW	5,5 kW	5,5 kW
Airblower with heater	-	750 Watt	750 Watt
Bypass for heat pump connection	yes	yes	yes
SKINOXYFORM (Oxygen therapy)	-	-	1,65 kW
UVZONATOR (Desinfection)	yes	yes	yes
<b>Peak Load</b>	<b>10,1 kW</b>	<b>10,86 kW</b>	<b>11,14 kW</b>

<b>CONTROL</b>			
Smart Spa Control	yes	yes	yes
Display	SSC.XE	SSC.XE	SSC.XE
WiFi	yes	yes	yes
Remote maintenance	yes	yes	yes
App control	yes	yes	yes
Voice control/Google/Alexa	-	-	yes

<b>COMFORT HIGHLIGHTS</b>			
Soundsystem: 4x Exciter 50W, 1x Subwoofer 100W	-	-	yes
Aromatherapy	-	yes	yes
Master LED	1	1	1
LED lighting/colour light therapy	10	190	190
waterfall illuminated	1	1	1

<b>MORE INFORMATION</b>			
Neck support illuminated	3	3	3
Cup holder illuminated	3	3	3
Tub draining	Standard	Deep draining	Deep draining

**Premium**

-  VARIOUS Jets
-  waterfall
-  Bypass
-  LED
-  UVZONATOR
-  cup holder
-  WiFi App control

**First Class**

-  Airblower mit Airjets
-  Aromatherapy
-  Tiefenentleerung
-  colour light therapy

**Luxury**

-  Soundsystem
-  Voice- & remote control
-  Skinoxyform

Protective Panel Standard  
Outer panelling



Protective Coat Standard  
Thermo cover



Thermal covers in black, brown and grey are not available for all models. Please check availability in advance. The Whirlcare® main standard colour is anthracite

# PERFECTION



# PERFECTION XE

Unique comfort in perfection

**5**

**1**

**96**

**VARIOUS**

**20**

**AIR**



	Premium	First Class	Luxury
<b>MASTER DATA</b>			
Measurements	215 x 215 x 92 cm	215 x 215 x 92 cm	215 x 215 x 92 cm
Seats	5	5	5
Loungers	1	1	1
Water volume	1030 L	1030 L	1030 L
Net weight	~399 kg	~407 kg	~422kg
Power supply	400 V / 25,25 A	400 V / 27,18 A	400 V / 27,88 A

<b>JETS</b>			
VARIOUS HYDROJETS (2"/3"/4")	96 (52/20/24)	96 (52/20/24)	96 (52/20/24)
Airjets	-	20	20
<b>Total</b>	<b>96</b>	<b>116</b>	<b>116</b>

<b>PERFORMANCE</b>			
HydroPowerPump	2x 2,2 kW	2x 2,2 kW	2x 2,2 kW
Circulation pump	200 Watt	200 Watt	200 Watt
Electric heating	5,5 kW	5,5 kW	5,5 kW
Airblower with heater	-	750 Watt	750 Watt
Bypass for heat pump connection	yes	yes	yes
SKINOXYFORM (Oxygen therapy)	-	-	1,65 kW
UVZONATOR (Desinfection)	yes	yes	yes
<b>Peak Load</b>	<b>10,1 kW</b>	<b>10,87 kW</b>	<b>11,15 kW</b>

<b>CONTROL</b>			
Smart Spa Control	yes	yes	yes
Display	SSC.XE	SSC.XE	SSC.XE
WiFi	yes	yes	yes
Remote maintenance	yes	yes	yes
App control	yes	yes	yes
Voice control/Google/Alexa	-	-	yes

<b>COMFORT HIGHLIGHTS</b>			
Soundsystem: 4x Exciter 50W, 1x Subwoofer 100W	-	-	yes
Aromatherapy	-	yes	yes
Master LED	1	1	1
LED lighting/colour light therapy	16	208	208
waterfall illuminated	1	1	1

<b>MORE INFORMATION</b>			
Neck support illuminated	6	6	6
Cup holder illuminated	6	6	6
Tub draining	Standard	Deep draining	Deep draining

Premium

  
VARIOUS Jets

  
waterfall

  
Bypass

  
LED

  
UVZONATOR

  
cup holder

  
WiFi  
App control

First Class

  
Airblower  
mit Airjets

  
Aroma-  
therapy

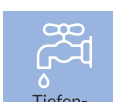
  
Tiefen-  
entleerung

  
colour light  
therapy

Luxury

  
Soundssystem

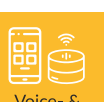
  
Voice- &  
remote control

  
Skinoxyform

Protective Panel Standard  
Outer panelling



Protective Coat Standard  
Thermo cover



Thermal covers in black, brown and grey are not available for all models.  
Please check availability in advance. The Whirlcare® main standard colour is anthracite

# EXCELLENCE



# EXCELLENCE XE

Excellent massage and wellness variety



	Premium	First Class	Luxury
<b>MASTER DATA</b>			
Measurements	225 x 225 x 90,5 cm	225 x 225 x 90,5 cm	225 x 225 x 90,5 cm
Seats	3	3	3
Loungers	2	2	2
Water volume	1225 L	1225 L	1225 L
Net weight	~342 kg	~353 kg	~370 kg
Power supply	230 V / 36 A	230 V / 39,4 A	230 V / 40,57 A
	400 V / 20,75 A	400 V / 22,65 A	400 V / 23,33 A

<b>JETS</b>			
VARIOUS HYDROJETS (2"/3"/4")	66 (32/22/12)	66 (32/22/12)	66 (32/22/12)
Airjets	-	16	16
Volcano jet	1	1	1
<b>Total</b>	<b>67</b>	<b>83</b>	<b>83</b>

<b>PERFORMANCE</b>			
HydroPowerPump	1x 2,6 kW	1x 2,6 kW	1x 2,6 kW
Circulation pump	200 Watt	200 Watt	200 Watt
Electric heating	5,5 kW	5,5 kW	5,5 kW
Airblower with heater	-	750 Watt	750 Watt
Bypass for heat pump connection	yes	yes	yes
SKINOXYFORM (Oxygen therapy)	-	-	1,65 kW
UVZONATOR (Desinfection)	yes	yes	yes
<b>Peak Load</b>	<b>8,3 kW</b>	<b>9,06 kW</b>	<b>9,33 kW</b>

<b>CONTROL</b>			
Smart Spa Control	yes	yes	yes
Display	SSC.XE	SSC.XE	SSC.XE
WiFi	yes	yes	yes
Remote maintenance	yes	yes	yes
App control	yes	yes	yes
Voice control/Google/Alexa	-	-	yes

<b>COMFORT HIGHLIGHTS</b>			
Soundsystem: 4x Exciter 50W, 1x Subwoofer 100W	-	-	yes
Aromatherapy	-	yes	yes
Master LED	1	1	1
LED lighting/colour light therapy	18	150	150
waterfall illuminated	1	1	1

<b>MORE INFORMATION</b>			
Neck support illuminated	5	5	5
Cup holder illuminated	5	5	5
Tube draining	Standard	Deep draining	Deep draining
Plug&Play	yes	yes	yes

**Premium**

- VARIOUS Jets
- Volcano jet
- Bypass
- waterfall
- UVZONATOR
- LED
- WiFi App control
- cup holder

**First Class**

- Airblower mit Airjets
- Aromatherapy
- Tiefenentleerung
- colour light therapy

**Luxury**

- Soundsystem
- Voice- & remote contro
- Skinioxyform

Protective Panel Standard  
Outer panelling



Protective Coat Standard  
Thermo cover



Thermal covers in black, brown and grey are not available for all models. Please check availability in advance. The Whirlcare® main standard colour is anthracite



# WAG WAG WAG



# MAGIC XE

## A magical hot tub composition



	Premium	First Class	Luxury
<b>MASTER DATA</b>			
Measurements	210 x 210 x 91,5 cm	210 x 210 x 91,5 cm	210 x 210 x 91,5 cm
Seats	4	4	4
Loungers	1	1	1
Water volume	1185 L	1185 L	1185 L
Net weight	~380 kg	~387 kg	~402 kg
Power supply	230 V / 36,1 A	230 V / 39,4 A	230 V / 40,6 A
	400 V / 20,75 A	400 V / 22,65 A	400 V / 23,35 A

<b>JETS</b>			
VARIOUS HYDROJETS (2"/3"/4")	66 (34/20/12)	66 (34/20/12)	66 (34/20/12)
Airjets	-	17	17
Volcano jet	1	1	1
<b>Total</b>	<b>67</b>	<b>84</b>	<b>84</b>

<b>PERFORMANCE</b>			
HydroPowerPump	1x 2,6 kW	1x 2,6 kW	1x 2,6 kW
Circulation pump	200 Watt	200 Watt	200 Watt
Electric heating	5,5 kW	5,5 kW	5,5 kW
Airblower with heater	-	750 Watt	750 Watt
Bypass for heat pump connection	yes	yes	yes
SKINOXYFORM (Oxygen therapy)	-	-	1,65 kW
UVZONATOR (Desinfection)	yes	yes	yes
Peak Load	8,3 kW	9,06 kW	9,34 kW

<b>CONTROL</b>			
Smart Spa Control	yes	yes	yes
Display	SSC.XE	SSC.XE	SSC.XE
WiFi	yes	yes	yes
Remote maintenance	yes	yes	yes
App control	yes	yes	yes
Voice control/Google/Alexa	-	-	yes

<b>COMFORT HIGHLIGHTS</b>			
Soundsystem: 4x Exciter 50W, 1x Subwoofer 100W	-	-	yes
Aromatherapy	-	yes	yes
Master LED	1	1	1
LED lighting/colour light therapy	14	122	122

<b>MORE INFORMATION</b>			
Neck support illuminated	5	5	5
Cup holder illuminated	6	6	6
Tub draining	Standard	Deep draining	Deep draining
Plug&Play	yes	yes	yes

Protective Panel Standard  
Outer panelling



Protective Coat Standard  
Thermo cover



Thermal covers in black, brown and grey are not available for all models.  
Please check availability in advance. The Whirlcare® main standard colour is anthracite

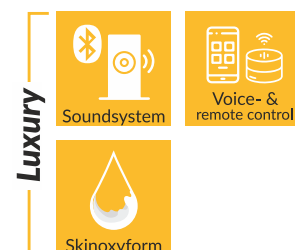
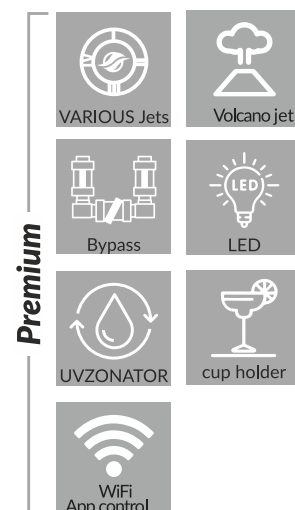

# TEAMPLAYERS



# TEAMPLAYER XE

The all-rounder for even more wellness



	Premium	First Class	Luxury
<b>MASTER DATA</b>			
Measurements	225 x 225 x 92,5 cm	225 x 225 x 92,5 cm	225 x 225 x 92,5 cm
Seats	7	7	7
Loungers	0	0	0
Water volume	1260 L	1260 L	1260 L
Net weight	~310 kg	~320 kg	~340 kg
Power supply	230 V / 36,1 A	230 V / 39,4 A	230 V / 40,6 A
	400 V / 20,75 A	400 V / 22,65 A	400 V / 23,35 A

<b>JETS</b>			
VARIOUS HYDROJETS (2"/3"/4")	60 (16/32/12)	60 (16/32/12)	60 (16/32/12)
Airjets	-	15	15
<b>Total</b>	<b>60</b>	<b>75</b>	<b>75</b>







<b>PERFORMANCE</b>			
HydroPowerPump	1x 2,57 kW	1x 2,57 kW	1x 2,57 kW
Circulation pump	200 Watt	200 Watt	200 Watt
Electric heating	5,5 kW	5,5 kW	5,5 kW
Airblower with heater	-	750 Watt	750 Watt
Bypass for heat pump connection	yes	yes	yes
SKINOXYFORM (Oxygen therapy)	-	-	1,65 kW
UVZONATOR (Desinfection)	yes	yes	yes
<b>Peak Load</b>	<b>8,3 kW</b>	<b>9,06 kW</b>	<b>9,34 kW</b>

<b>CONTROL</b>			
Smart Spa Control	yes	yes	yes
Display	SSC.XE	SSC.XE	SSC.XE
WiFi	yes	yes	yes
Remote maintenance	yes	yes	yes
App control	yes	yes	yes
Voice control/Google/Alexa	-	-	yes





<b>COMFORT HIGHLIGHTS</b>			
Soundsystem: 4x Exciter 50W, 1x Subwoofer 100W	-	-	yes
Aromatherapy	-	yes	yes
Master LED	1	1	1
LED lighting/colour light therapy	14	134	134

<b>MORE INFORMATION</b>			
Neck support illuminated	7	7	7
Cup holder illuminated	7	7	7
Tub draining	Standard	Deep draining	Deep draining
Plug&Play	yes	yes	yes



**Premium**

-   
VARIOUS Jets
-   
LED
-   
Bypass
-   
cup holder
-   
UVZONATOR
-   
WiFi App control

**First Class**

-   
Airblower with Airjets
-   
Aroma-therapy
-   
Tiefen-entleerung
-   
colour light therapy

**Luxury**

-   
Soundsystem
-   
Voice- & remote control
-   
Skinoxyform

Protective Panel Standard  
Outer panelling



Protective Coat Standard  
Thermo cover



Thermal covers in black, brown and grey are not available for all models.  
Please check availability in advance. The Whirlcare® main standard colour is anthracite

FE

AS

FE

AS

FE

AS

FE



# RELEASE XE-S

Impressive entry-level model



	Premium	First Class	Luxury
<b>MASTER DATA</b>			
Measurements	228 x 228 x 86 cm	228 x 228 x 86 cm	228 x 228 x 86 cm
Seats	3	3	3
Loungers	2	2	2
Water volume	1175 L	1175 L	1175 L
Net weight	~322 kg	~330 kg	~340 kg
Power supply	230 V / 34,35 A	230V / 37,65 A	230 V / 38,83 A

<b>JETS</b>			
VARIOUS HYDROJETS (2"/3"/4")	36 (4/14/18)	36 (4/14/18)	36 (4/14/18)
Airjets	-	8	8
<b>Total</b>	<b>36</b>	<b>44</b>	<b>44</b>

<b>PERFORMANCE</b>			
HydroPowerPump	1x 2,2 kW	1x 2,2 kW	1x 2,2 kW
Circulation pump	200 Watt	200 Watt	200 Watt
Electric heating	5,5 kW	5,5 kW	5,5 kW
Airblower with heater	-	750 Watt	750 Watt
Bypass for heat pump connection	yes	yes	yes
SKINOXYFORM (Oxygen therapy)	-	-	1,65 kW
UVZONATOR (Desinfection)	yes	yes	yes
<b>Peak Load</b>	<b>7,9 kW</b>	<b>8,66 kW</b>	<b>8,93 kW</b>

<b>CONTROL</b>			
Smart Spa Control	yes	yes	yes
Display	SSC.XE-S	SSC.XE-S	SSC.XE-S
WiFi	yes	yes	yes
Remote maintenance	yes	yes	yes
App control	yes	yes	yes
Voice control/Google/Alexa	-	-	yes

<b>COMFORT HIGHLIGHTS</b>			
Soundsystem: 4x Exciter 50W, 1x Subwoofer 100W	-	-	yes
Master LED	1	1	1
LED lighting/colour light therapy	9	9	9
waterfall illuminated	1	1	1

<b>MORE INFORMATION</b>			
Neck support illuminated	5	5	5
Cup holder (Vertiefung)	5	5	5
Tub draining	Standard	Standard	Standard
Plug&Play	yes	yes	yes

Protective Panel Standard  
Outer panelling



Protective Coat Standard  
Thermo cover



Thermal covers in black, brown and grey are not available for all models.  
Please check availability in advance. The Whirlcare® main standard colour is anthracite

**Premium**

- VARIOUS Jets
- waterfall
- Bypass
- LED
- UVZONATOR
- cup holder
- WiFi App control

**First Class**

- Airblower with Airjets
- colour light therapy

**Luxury**

- Soundsystem
- Voice- & remote control
- Skinioxyform

# ARTWORK



# ARTWORK XE-S

A true hot tub work of art



	Premium	First Class	Luxury
<b>MASTER DATA</b>			
Measurements	225 x 225 x 86 cm	225 x 225 x 86 cm	225 x 225 x 86 cm
Seats	5	5	5
Loungers	1	1	1
Water volume	1190 L	1190 L	1190 L
Net weight	~370 kg	~377 kg	~392 kg
Power supply	230 V / 34,35 A	230 V / 37,65 A	230 V / 38,83 A

<b>JETS</b>			
VARIOUS HYDROJETS (2"/3"/4")	32 (4/14/14)	32 (4/14/14)	32 (4/14/14)
Airjets	-	10	10
<b>Total</b>	<b>32</b>	<b>42</b>	<b>42</b>

<b>PERFORMANCE</b>			
HydroPowerPump	1x 2,2 kW	1x 2,2 kW	1x 2,2 kW
Circulation pump	200 Watt	200 Watt	200 Watt
Electric heating	5,5 kW	5,5 kW	5,5 kW
Airblower with heater	-	750 Watt	750 Watt
Bypass for heat pump connection	yes	yes	yes
SKINOXYFORM (Oxygen therapy)	-	-	1,65 kW
UVZONATOR (Desinfection)	yes	yes	yes
<b>Peak Load</b>	<b>7,9 kW</b>	<b>8,66 kW</b>	<b>8,93 kW</b>

<b>CONTROL</b>			
Smart Spa Control	yes	yes	yes
Display	SSC.XE-S	SSC.XE-S	SSC.XE-S
WiFi	yes	yes	yes
Remote maintenance	yes	yes	yes
App control	yes	yes	yes
Voice control/Google/Alexa	-	-	yes

<b>COMFORT HIGHLIGHTS</b>			
Soundssystem: 4x Exciter 50W, 1x Subwoofer 100W	-	-	yes
Master LED	1	1	1
LED lighting/colour light therapy	10	10	10
waterfall illuminated	1	1	1

<b>MORE INFORMATION</b>			
Neck support illuminated	6	6	6
Cup holder (Vertiefung)	6	6	6
Tub draining	Standard	Standard	Standard
Plug&Play	yes	yes	yes

Protective Panel Standard  
Outer panelling



Protective Coat Standard  
Thermo cover



Thermal covers in black, brown and grey are not available for all models.  
Please check availability in advance. The Whirlcare® main standard colour is anthracite

**Premium**

- VARIOUS Jets
- waterfall
- Bypass
- LED
- UVZONATOR
- cup holder
- WiFi App control

**First Class**

- Airblower with Airjets
- colour light therapy

**Luxury**

- Soundssystem
- Voice- & remote control
- Skinoxyform

# WPPERSSION





# IMPRESSION XE-S

An impression of luxury and relaxation









	Premium	First Class	Luxury
<b>MASTER DATA</b>			
Measurements	220 x 123 x 82 cm	220 x 123 x 82 cm	220 x 123 x 82 cm
Seats	2	2	2
Loungers	0	0	0
Water volume	520 L	520 L	520 L
Net weight	~271 kg	~276 kg	~291 kg
Power supply	230 V / 34,35 A	230 V / 37,65 A	230 V / 38,83 A

	Premium	First Class	Luxury
<b>JETS</b>			
VARIOUS HYDROJETS (2"/3"/4")	18 (6/12/-)	18 (6/12/-)	18 (6/12/-)
Airjets	-	6	6
<b>Total</b>	<b>18</b>	<b>24</b>	<b>24</b>

	Premium	First Class	Luxury
<b>PERFORMANCE</b>			
HydroPowerPump	1x 2,2 kW	1x 2,2 kW	1x 2,2 kW
Circulation pump	200 Watt	200 Watt	200 Watt
Electric heating	5,5 kW	5,5 kW	5,5 kW
Airblower with heater	-	750 Watt	750 Watt
Bypass for heat pump connection	yes	yes	yes
SKINOXYFORM (Oxygen therapy)	-	-	1,65 kW
UVZONATOR (Desinfection)	yes	yes	yes
<b>Peak Load</b>	<b>7,9 kW</b>	<b>8,66 kW</b>	<b>8,93 kW</b>

	Premium	First Class	Luxury
<b>CONTROL</b>			
Smart Spa Control	yes	yes	yes
Display	SSC.XE-S	SSC.XE-S	SSC.XE-S
WiFi	yes	yes	yes
Remote maintenance	yes	yes	yes
App control	yes	yes	yes
Voice control/Google/Alexa	-	-	yes

	Premium	First Class	Luxury
<b>COMFORT HIGHLIGHTS</b>			
Soundsystem: 4x Exciter 50W, 1x Subwoofer 100W	-	-	yes
Master LED	1	1	1

	Premium	First Class	Luxury
<b>MORE INFORMATION</b>			
Neck support illuminated	-	-	-
Cup holder (Vertiefung)	2	2	2
Tub draining	Standard	Standard	Standard
Plug&Play	yes	yes	yes

Protective Panel Standard  
Outer panelling





Protective Coat Standard  
Thermo cover





Thermal covers in black, brown and grey are not available for all models.  
Please check availability in advance. The Whirlcare® main standard colour is anthracite

Premium

  
VARIOUS Jets

  
waterfall

  
Bypass

  
LED

  
UVZONATOR

  
cup holder

  
WiFi  
App control

First Class

  
Airblower  
with Airjets

Luxury

  
Soundsystem

  
Voice- &  
remote control

  
Skinoxyform

The illustrations of the products or their components may differ from the original. Subject to technical changes.

81

# THE NEW D



# IDENTITY XE-S

Discover your true identity









	Premium	First Class	Luxury
<b>MASTER DATA</b>			
Measurements	208 x 170 x 88 cm	208 x 170 x 88 cm	208 x 170 x 88 cm
Seats	1	1	1
Loungers	1	1	1
Water volume	985 L	985 L	985 L
Net weight	~295 kg	~305 kg	~325 kg
Power supply	230 V / 34,35 A	230 V / 37,65 A	230 V / 38,83 A

<b>JETS</b>			
VARIOUS HYDROJETS (2"/3"/4")	36 (30/2/4)	36 (30/2/4)	36 (30/2/4)
Airjets	-	6	6
<b>Total</b>	<b>36</b>	<b>42</b>	<b>42</b>

<b>PERFORMANCE</b>			
HydroPowerPump	1x 2,2 kW	1x 2,2 kW	1x 2,2 kW
Circulation pump	200 Watt	200 Watt	200 Watt
Electric heating	5,5 kW	5,5 kW	5,5 kW
Airblower with heater	-	750 Watt	750 Watt
Bypass for heat pump connection	yes	yes	yes
SKINOXYFORM (Oxygen therapy)	-	-	1,65 kW
UVZONATOR (Desinfection)	yes	yes	yes
<b>Peak Load</b>	<b>7,9 kW</b>	<b>8,66 kW</b>	<b>8,93 kW</b>

<b>CONTROL</b>			
Smart Spa Control	yes	yes	yes
Display	SSC.XE-S	SSC.XE-S	SSC.XE-S
WiFi	yes	yes	yes
Remote maintenance	yes	yes	yes
App control	yes	yes	yes
Voice control/Google/Alexa	-	-	yes

<b>COMFORT HIGHLIGHTS</b>			
Soundssystem: 4x Exciter 50W, 1x Subwoofer 100W	-	-	yes
Master LED	1	1	1
Beleuchtung LED	2	2	2

<b>MORE INFORMATION</b>			
Neck support illuminated	2	2	2
Cup holder (Vertiefung)	2	2	2
Tube draining	Standard	Standard	Standard
Plug&Play	yes	yes	yes

Protective Panel Standard  
Outer panelling



Protective Coat Standard  
Thermo cover



Thermal covers in black, brown and grey are not available for all models.  
Please check availability in advance. The Whirlcare® main standard colour is anthracite

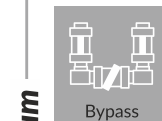

Fascination Swim-Spa  
Models of the new generation

# SURFER WELLPOWER FAMILY





# SWIM SPA



# SURFER

Pure swim-spa enjoyment

 +Swimmer 
  2 Whirl-Seats 
  1 Relax-Seat 
  42 VARIOUS 
  5 COUNTERFLOW 
  12 AIR



	Premium	First Class
<b>MASTER DATA</b>	Swim-Spa	Swim-Spa
Measurements	430 x 230 x 150 cm	430 x 230 x 150 cm
Whirl-Seats	2	2
Relax-Seats	1	1
Water volume	6.150 L	6.150 L
Net weight	~1.100 kg	~1.110 kg
Power supply	400 V / 33,25 A	230 V / 35,75 A

JETS	Swim-Spa	Swim-Spa
VARIOUS HYDROJETS (2"/3"/4")	42	42
Counterflow Jets	5	5
Airjets	-	12
<b>Total</b>	<b>47</b>	<b>59</b>

PERFORMANCE	Swim-Spa	Swim-Spa
HydroPowerPump	4 x 1,85 kW	4 x 1,85 kW
Circulation pump	400 Watt	400 Watt
Airblower with heater	-	750 Watt
Bypass for heat pump connection	yes	yes
Electric heating	5,5 kW	5,5 kW
UVZONATOR (Desinfection)	yes	yes
<b>Peak Load</b>	<b>13,3 kW</b>	<b>14,3 kW</b>

CONTROL	Swim-Spa	Swim-Spa
Smart Spa Control	yes	yes
Display	SSC.XE	SSC.XE
WiFi	yes	yes
Remote maintenance	yes	yes
App control	yes	yes
Voice control/Google/Alexa	-	yes

COMFORT HIGHLIGHTS	Swim-Spa	Swim-Spa
Soundsystem: 4x Exciter 50W, 1x Subwoofer 100W	-	yes
Underwater-LED	3	3
LED lighting/colour light therapy	69	153

MORE INFORMATION	Swim-Spa	Swim-Spa
Neck support	2	2
Cup holder illuminated	5	5
Tub draining	Standard	Standard

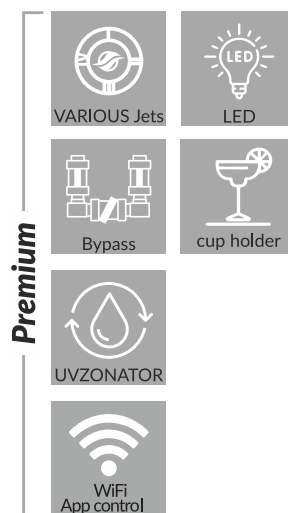

Protective Panel Standard  
Outer panelling



Protective Coat Standard  
Thermo cover



Thermal covers in black, brown and grey are not available for all models.  
Please check availability in advance. The Whirlcare® main standard colour is anthracite

# WELLPOWER



SWIM-SPA EDITION  
*Wellpower*



# WELLPOWER

Hot tub + swim spa in one

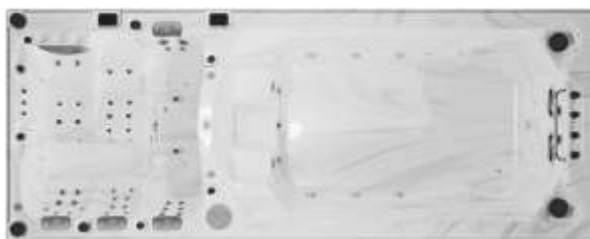

	Premium		First Class		Luxury	
MASTER DATA 2-chamber system	Hot tub	Swim-Spa	Hot tub	Swim-Spa	Hot tub	Swim-Spa
Measurements	587 x 230 x 160 cm		587 x 230 x 160 cm		587 x 230 x 160 cm	
Seats	2	-	2	-	2	-
Loungers	2	-	2	-	2	-
Water volume	1.350 L	7.150 L	1.350 L	7.150 L	1.350 L	7.150 L
Net weight	~1.500kg		~1.500kg		~1.500kg	
Power supply	400 V		400 V		400 V	
Amperage	24,5 A	33,25 A	26,5 A	33,25 A	27,25 A	33,25 A
<b>JETS</b>	Hot tub	Swim-Spa	Hot tub	Swim-Spa	Hot tub	Swim-Spa
VARIOUS HYDROJETS (2"/3"/4")	38 (18/18/2)	-	38 (18/18/2)	-	38 (18/18/2)	-
Counterflow Jets	-	6	-	6	-	6
Airjets	-	-	12	-	12	-
<b>Total</b>	<b>44</b>		<b>56</b>		<b>56</b>	
<b>PERFORMANCE</b>	Hot tub	Swim-Spa	Hot tub	Swim-Spa	Hot tub	Swim-Spa
HydroPowerPump	1 x 2,20 kW + 1 x 1,85 kW	4 x 1,85 kW	1 x 2,20 kW + 1 x 1,85 kW	4 x 1,85 kW	1 x 2,20 kW + 1 x 1,85 kW	4 x 1,85 kW
Circulation pump	300 Watt	400 Watt	300 Watt	400 Watt	300 Watt	400 Watt
Airblower with heater	-	-	750 Watt	-	750 Watt	-
Electric heating	5,5 kW	5,5 kW	5,5 kW	5,5 kW	5,5 kW	5,5 kW
Bypass for heat pump connection	yes	yes	yes	yes	yes	yes
SKINOXYFORM (Oxygen therapy)	-	-	-	-	yes	-
UVZONATOR (Desinfection)	yes	Ozonator	yes	Ozonator	yes	Ozonator
Peak Load	9,85 kW	13,3 kW	9,85 kW	13,3 kW	9,85 kW	13,3 kW
<b>CONTROL</b>	Hot tub	Swim-Spa	Hot tub	Swim-Spa	Hot tub	Swim-Spa
Smart Spa Control	yes	yes	yes	yes	yes	yes
Display	SSC.XE	SSC.XE	SSC.XE	SSC.XE	SSC.XE	SSC.XE
WiFi	yes	yes	yes	yes	yes	yes
Remote maintenance	yes	yes	yes	yes	yes	yes
App control	yes	yes	yes	yes	yes	yes
Voice control/Google/Alexa	-	-	-	-	yes	yes
<b>COMFORT HIGHLIGHTS</b>	Hot tub	Swim-Spa	Hot tub	Swim-Spa	Hot tub	Swim-Spa
Soundsystem: 4x Exciter 50W, 1x Subwoofer 100W	-	-	yes	-	yes	-
Aromatherapy	-	-	yes	-	yes	-
Underwater-LED	-	3	-	3	-	3
LED lighting/colour light therapy	20	54	96	54	96	54
Fountain illuminated	3	-	3	-	3	-
<b>Total number LED illuminated</b>	<b>80</b>		<b>156</b>		<b>156</b>	
<b>MORE INFORMATION</b>	Hot tub	Swim-Spa	Hot tub	Swim-Spa	Hot tub	Swim-Spa
Neck support	4	-	4	-	4	-
Cup holder illuminated	3	-	3	-	3	-
Tub draining	Standard	Standard	Standard	Standard	Standard	Standard

**Premium**

- VARIOUS Jets
- Fountains
- Bypass
- LED
- UVZONATOR
- Ozonator
- WiFi App control
- cup holder

**First Class**

- Airblower with Airjets
- Aromatherapy
- colour light therapy

**Luxury**

- Soundsystem
- Voice- & remote control
- Skinoxyform

Protective Panel Standard  
Outer panelling

White
 Anthracite

Protective Coat Standard  
Thermo cover

Anthracite
 Black
 Brown
 Grey

Thermal covers in black, brown and grey are not available for all models.  
Please check availability in advance. The Whirlcare® main standard colour is anthracite

# FAV



# FAMILY

Fascinating swim spa for the whole family



	<b>3</b>	<b>1</b>	<b>38</b>	<b>12</b>
	<b>2</b>	<b>28</b>	<b>6</b>	

	<b>Premium</b>		<b>First Class</b>		<b>Luxury</b>	
<b>MASTER DATA</b> 2-chamber system	Hot tub	Swim-Spa	Hot tub	Swim-Spa	Hot tub	Swim-Spa
Measurements	587 x 230 x 150 cm		587 x 230 x 150 cm		587 x 230 x 150 cm	
Seats	3	2	3	2	3	2
Loungers	1	-	1	-	1	-
Water volume	1.180 L	6.898 L	1.180 L	6.898 L	1.180 L	6.898 L
Net weight	~1.380 kg		~1.380 kg		~1.380 kg	
<b>Power supply</b>	400 V		400 V		400 V	
<b>Amperage</b>	20 A	33,25 A	21,9 A	33,27 A	26,7 A	33,27 A
<b>JETS</b>	Hot tub	Swim-Spa	Hot tub	Swim-Spa	Hot tub	Swim-Spa
VARIOUS HYDROJETS (2"/3"/4")	<b>38</b> (32/2/4)	<b>28</b> (18/6/4)	<b>38</b> (32/2/4)	<b>28</b> (18/6/4)	<b>38</b> (32/2/4)	<b>28</b> (18/6/4)
Counterflow Jets	-	3	-	3	-	3
Airjets	-	-	12	-	12	-
<b>Total</b>	<b>69</b>		<b>81</b>		<b>81</b>	
<b>PERFORMANCE</b>	Hot tub	Swim-Spa	Hot tub	Swim-Spa	Hot tub	Swim-Spa
HydroPowerPump	1 x 2,20 kW	4 x 1,85 kW	1 x 2,20 kW	4 x 1,85 kW	1 x 2,20 kW	4 x 1,85 kW
Circulation pump	300 Watt	400 Watt	300 Watt	400 Watt	300 Watt	400 Watt
Airblower with heater	-	-	750 Watt	-	750 Watt	-
Electric heater	5,5 kW	5,5 kW	5,5 kW	5,5 kW	5,5 kW	5,5 kW
Bypass for heat pump connection	yes	yes	yes	yes	yes	yes
SKINOXYFORM (Oxygen therapy)	-	-	-	-	yes	-
UVZONATOR (Desinfection)	yes	Ozonator	yes	Ozonator	yes	Ozonator
<b>Peak Load</b>	<b>8,0 kW</b>	<b>13,3 kW</b>	<b>8,76 kW</b>	<b>13,31 kW</b>	<b>10,68 kW</b>	<b>13,31 kW</b>
<b>CONTROL</b>	Hot tub	Swim-Spa	Hot tub	Swim-Spa	Hot tub	Swim-Spa
Smart Spa Control	yes	yes	yes	yes	yes	yes
Display	SSC.XE	SSC.XE	SSC.XE	SSC.XE	SSC.XE	SSC.XE
WiFi	yes	yes	yes	yes	yes	yes
Remote maintenance	yes	yes	yes	yes	yes	yes
App control	yes	yes	yes	yes	yes	yes
Voice control/Google/Alexa	-	-	-	-	-	yes
<b>COMFORT HIGHLIGHTS</b>	Hot tub	Swim-Spa	Hot tub	Swim-Spa	Hot tub	Swim-Spa
Soundsystem: 4x Exciter 50W, 1x Subwoofer 100W	-	-	-	-	yes	
Aromatherapy	-	-	yes	-	yes	-
Underwater-LED	1	2	1	2	1	2
LED lighting/colour light therapy	20	44	96	100	96	100
<b>Total number LED illuminated</b>	<b>67</b>		<b>199</b>		<b>199</b>	
<b>MORE INFORMATION</b>	Hot tub	Swim-Spa	Hot tub	Swim-Spa	Hot tub	Swim-Spa
Neck support	4	1	4	1	4	1
Cup holder illuminated	2	-	2	-	2	-
Tub draining	Standard	Standard	Standard	Standard	Standard	Standard

**Premium**

- VARIOUS Jets
- LED
- Bypass
- cup holder
- UVZONATOR
- Ozonator
- WiFi App Control

**First Class**

- Airblower with Airjets
- Aromatherapy
- colour light therapy

**Luxury**

- Soundsystem
- Voice- & remote control
- Skinoxyform

Protective Panel Standard Outer panelling

	White		Anthracite
--	-------	--	------------

Protective Coat Standard Thermo cover

	Anthracite		Black		Brown		Grey
--	------------	--	-------	--	-------	--	------

Thermal covers in black, brown and grey are not available for all models. Please check availability in advance. The Whirlcare® main standard colour is anthracite

The illustrations of the products or their components may differ from the original. Subject to technical changes.



WHIRLCARE

# FACTS

## The new generation of wellness

Whirlcare® Whirlpools & Swim-Spas

Our XE models have earned the reputation of being the best hot tubs in the world - and not only our satisfied customers claim this, but also renowned whirlpool specialist dealers. However, we do not make this claim ourselves, but boldly face up to the global competition. Any manufacturer who claims to build better whirlpools than Whirlcare® and can justify this objectively will be met with an open discussion. We counter anyone who dares to make a comparison with a multitude of equally objective arguments. Because we are convinced that all facts and advantages count in such a competition - not just individual aspects. We are passionate about creating an incomparable wellness experience. With Whirlcare® you can rely on quality, innovation and virtually unsurpassed relaxation. Discover the unbeatable features of our whirlpools: high-quality materials, pioneering technology, first-class workmanship and an aesthetic design. Thanks to continuous research and development, we are always able to offer you the latest features and functions.

## Further features

that most manufacturers do not talk about

Read on the following pages

- The deliberate avoidance of water fountains
- The SleepTimer in the Smart Spa Control (Solar & Smart Meter)
- Artificial intelligence in the integrated electric heater
- Water characteristic curve - The correct water level
- Variable ABS plastic supports
- Current limitation / load limitation



## Deliberately no water fountain

### Avoidance of standing water in the pipes & hoses

We deliberately do without water fountains in our whirlpools. Why? Because we prioritize your safety and the preservation of your Protective Coat. Other hot tubs rely on water fountains that are aimed directly at the underside of the cover as the water circulates. But here's the problem: if these fountains are closed properly, they can cause standing water in the pipes. This can lead to undesirable consequences. At Whirlcare® we take a different approach. Our innovative whirlpools are designed to work without water fountains. This avoids potential problems such as standing water and allows you to use your whirlpool without any worries. This is because standing water in the pipes of your hot tub has various undesirable effects:

**Hygienic problems:** Stagnant water in the pipes can lead to an increased likelihood of bacterial and mold growth, algae and biofilm. This can affect water quality and pose a potential health risk to those using the spa.

**Odor development:** If hot water stands in the pipes for a long time, an unpleasant odor may develop. This is often caused by the growth of bacteria and other microorganisms.

**Reduced water quality:** The stagnant water can cause dirt, deposits and chemicals to accumulate in the pipes. This can impair the water quality, which can lead to turbidity and undesirable chemical reactions.

**Blockages:** Deposits and dirt particles that accumulate in standing water can clog the jets and pipes and obstruct the water flow. This can lead to inefficient water distribution and impaired function of the whirlpool.

**System damage:** Prolonged standing water in the pipes can also lead to corrosion and damage to the spa components. This can lead to malfunctions, leaks and possibly expensive repairs.

## Artificial intelligence

### High performance in the integrated electric heater



The integrated electric heating in the Smart Spa Control with an impressive variable output of up to 5.25 KW

Get the most out of your energy efficiency with our pioneering AI-supported variable heating. Put an end to excessive energy consumption - our intelligent system ensures that only as much energy is used as is actually needed. Our electric heater with an impressive output of up to 5.25 KW brings your whirlpool water to the desired temperature faster than conventional electric tube heaters. Enjoy rapid heating and get into your warm and relaxing bath faster. But what makes our variable heater truly unique is its ability to automatically adapt to demand. It continuously adjusts the output depending on how much heating power is required. This not only saves energy, but also makes operation more efficient.

Immerse yourself in a world where efficiency and comfort go hand in hand and experience a spa experience based on your individual needs. Find out more about how our intelligent heating works and the many benefits it offers in the Smart Spa Control chapter.



## Water characteristic curve

### The right water level

With our innovative water characteristic curve, monitoring and adjusting the water level is child's play. In the center of the dazzling cover of the skimmer is the Whirlcare® logo - your reliable indicator for the ideal water level. When the water is between the lower and upper edge of the Whirlcare® logos, you have the perfect water level reached. This ensures that your hot tub functions optimally and that you can enjoy an incomparable bathing and wellness experience. Our water level measuring system is not only practical, but also aesthetically pleasing. The Whirlcare® logo blends seamlessly into the design of your hot tub and is an eye-catcher for any onlooker. You can easily read the water level and ensure that it is always in the optimum range. It is important that the water curve is always above the uppermost jets so that they are always covered with water. This ensures that the jets work efficiently and can give you the massage you want.



## Variable ABS supports

### Stability and sustainability combined

For structural reasons, the whirlpool tub is additionally supported at several points between the floor and the tub body. But we go one step further to guarantee you the best quality. Instead of using cheap, impregnated wood, at Whirlcare we use innovative and recyclable ABS plastic supports. These variably adjustable supports ensure reliable support and stabilization of the tub. Thanks to their flexible adaptability, we can provide each tub with individual static support and thus ensure optimum balance and stability.



# The inventor of the smart spa WHIRLCARE MEETS AI



Welcome to the future of the  
spa & wellness industry

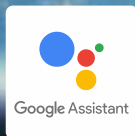





# Smart Technology

## Current and load limiting function

With our innovative Smart Technology controller, you have full control over your spa and can effectively reduce power consumption. Whether on site at the installation point or conveniently via remote access - you can adjust the settings so that they are within the limits of the available power supply. Thanks to the current limiting function, you can regulate the size of the heating element and thus precisely control energy consumption. By adjusting the power of the heating element, you ensure that your spa is heated optimally without overloading the capacity of your power supply. This means you save energy and reduce your electricity costs at the same time. But it's not just the heating that is taken into account. Our intelligent load limiting function allows you to regulate the pumps and blowers in your hot tub. By adjusting the power consumption of these components, you ensure that the power consumption remains within the available capacity. In this way, you avoid unnecessary loads on your power supply and ensure efficient operation of your hot tub. Our controller offers you the flexibility to adjust the power consumption precisely to your requirements and local conditions. Regardless of whether you want to set the controller on site or conveniently via remote access - you have full control over the energy efficiency of your hot tub. Save electricity, reduce your costs and enjoy the full hot tub experience at the same time.

 **Current limitation**  
(variable heating element)  
Controls the size of the heating element

 **Load limitation**  
Controls the pumps/blowers

Current and load limitation is important for different house connections, e.g. in Mediterranean countries such as Italy, Spain or France

## Solar & Smart Meter Ready

### Der SleepTimer in the smart spa control

With our innovative sleep timers and the energy-saving timer, you have full control over when your spa is active and when it is idle. Take advantage of solar panels or smart electricity meters to benefit from cheaper electricity tariffs at certain times of the day. Thanks to our smart timer functions, you can avoid wasting energy unnecessarily during periods when your hot tub is not in use. Other hot tub controls often don't even offer a single timer. With Newton's Law of Cooling in mind, we know that the greater the temperature difference between the water and the ambient temperature, the faster heat loss will occur. If you don't set a sleep timer, your hot tub will lose heat quickly and then heat up again in a continuous cycle - around the clock. This leads to enormous power consumption. By using our sleep timer, the loss of heat during rest periods is slowed down. This means that less heating power is required to restore the water temperature after a period of inactivity. In comparison, a hot tub that is kept at a set temperature around the clock would consume significantly more energy.

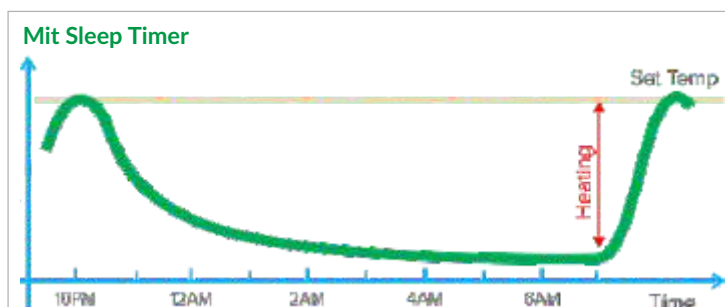
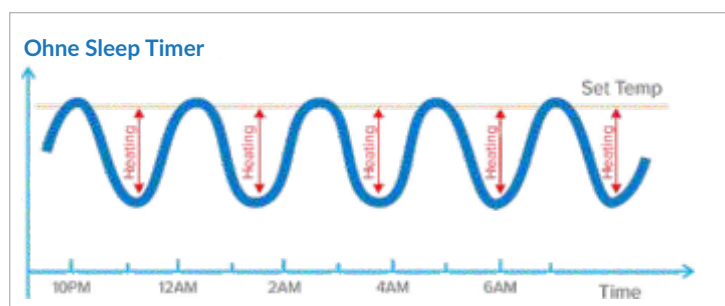

This means that less heating power is required to restore the water temperature after a so-called inactivity phase. In comparison, a hot tub that is kept at a set temperature around the clock would consume significantly more energy. With our sleep timer, you can achieve truly impressive energy savings of 25-35% per day. Compared to a hot tub without a timer, this means less power consumption and lower costs for you. Based on a 1,500 l hot tub, set at 38°C and a standard sleep timer from 22:00 to 07:00, you save money and protect the environment at the same time





*Take*

responsibility. For the region, the economy  
and the environment



From design, thermoforming, reinforcing and cutting to final assembly, quality assurance and storage, all work processes are interlinked and coordinated. With our decision to rely on the special polyurethane and the use of robots and driverless transport systems, we not only offer an environmentally friendly alternative, but also create safe working conditions for our employees.



## Home, energy, future Headquarter Whirlcare Industries GmbH

The declared goal of becoming one of the most sustainable and modern production facilities in the industry in Europe and around the world has been successfully completed. The construction phase of a further production hall and a separate central warehouse with a total of approx. 8,000 m<sup>2</sup>, as well as approx. 80 new parking spaces for employees, has been completed since 2022 and has now been expanded to 62,000 m<sup>2</sup> of land and more than 30,000 m<sup>2</sup> of production area. As part of this expansion, production is already almost climate-neutral thanks to the company's own electricity generation on the roofs and the exclusive use of recyclable and sustainable materials, thus taking climate and environmental protection into account. Shortly afterwards, the second construction phase was also completed specifically for the production of industry standard 4.0 freestanding swimming pools with counter-current systems, or swim spas for short. This means that the steadily increasing demand in this market segment can be optimally met. The adjacent central warehouse now ensures that customers no longer have to wait weeks or months for their goods! Whirlcare® Industries clearly sets itself apart from competitors from the Far East or overseas! The new building was not only used to expand existing production processes, but also to further optimize the process by separating the whirlpools and swim spas! Whirlcare® Industries and Spas United Group GmbH have contributed to the added value of the districts in Quellenland and the regional economy. In this company, energy, digitalization, innovation and industry standard 4.0 and, above all, sustainability are top priorities. Driverless transport systems, digital networking of the various intersections and sustainable energy-saving modifications ensure a sustainable process flow and guarantee quality made in Germany!



- World's first manufacturer in the industry with climate-positive production
- More than 80% of the materials used are recyclable or already made from recycled material
- A company with a sustainability strategy for the future

# Automated production processes

Networked intralogistics

## FULLY AUTOMATED



Whirlcare® whirlpools and swim spas are manufactured in the Swabian town of Deißlingen-Lauffen near Rottweil. Industry standard 4.0 production with fully automated, robot-supported manufacturing processes and networked intralogistics - including AI-supported production processes since 2023 - guarantees consistently high quality while taking ecological and economic aspects into account. The whirlpool and swim spa tubs are formed by huge machines specially made for Whirlcare® using the vacuum thermoforming process and then reinforced fully automatically. Swim spas with a length of up to twelve meters - the largest in the world - can be manufactured here.

### Deep drawing manufacturing process

At Whirlcare®, we attach great importance to the quality of our whirlpools and also to a sustainable manufacturing process. A decisive component of this is the thermoforming of the sanitary acrylic whirlpool tub, which enables precise and high-quality shaping. For thermoforming, the sanitary acrylic sheet material is heated from both sides individually depending on the thermoforming shape. Normally, inexpensive and conventional infrared heaters are used for this. At Whirlcare, however, we use special halogen heaters, which have a number of advantages. These halogen / quartz radiators offer 100% output from the outset, unlike infrared radiators, which require a certain amount of time for the heating process. However, the use of halogen/quartz heaters not only has the advantage of rapid heating, but also a significantly higher energy efficiency. This enables us to achieve impressive energy savings of around 25% in the deep-drawing process. These savings are not only good for the environment, but also contribute to the cost efficiency of our production. But that's not all - we go one step further. To cover the energy requirements for the thermoforming process, we mainly rely on our in-house photovoltaic system. By using solar energy, we produce a large part of the energy we need ourselves, which reduces our ecological footprint.

### Coating of the tub body

At Whirlcare, we use state-of-the-art technology not only to produce high-quality hot tubs, but also to help protect the environment. An important step in this process is the use of special polyurethane (PU) for our tubs. At Whirlcare, we use robots to apply the PU material evenly. This automated approach ensures consistent and high quality. Our special PU material is recyclable. This means that the tubs can be returned to the material cycle at the end of their life cycle instead of ending up in landfill. In contrast to many other manufacturers who still use environmentally harmful glass fiber reinforced plastic (GRP) to reinforce trays, we are taking the sustainable route. GRP is not only harmful to the environment, it is also not recyclable. In addition, the processing of GRP poses health risks for employees. With our decision to rely on the special polyurethane and the use of robots, we not only offer an environmentally friendly alternative, but also create safe working conditions for our employees.



## Drilling, milling, quality

At Whirlcare, we make no compromises when it comes to quality and precision. That's why we use the latest technology to drill and mill all the necessary holes in our hot tubs. Our robotic milling center, equipped with four ABB robots, ensures consistent and accurate execution of every single drilling and milling operation. Why is this so important? Well, the precise alignment of the holes at a 90° angle to the tub is crucial to ensure the jets are tight. Our robots use their skills to drill each hole with absolute precision. As a result, you can rest assured that your whirlpool jets will continue to function perfectly even after years of use and that no unwanted leaks will occur. Compared to manual work, the use of our robots offers a significant increase in quality. Thanks to their consistent precision and speed, they enable error-free drilling and milling. The result is whirlpools that are perfected down to the smallest detail and meet the highest standards. Choose Whirlcare and experience the precision of our robots in every single hot tub. Enjoy the reassuring feeling that every drill hole and cut has been carried out precisely and professionally. Quality is our top priority and we do everything we can to offer you a unique and flawless hot tub experience.



## Quality control

Stress test, long-term operation & climate chamber test



t Whirlcare®, we focus on the highest standards and quality assurance to ensure that our hot tub models meet your requirements in every respect. For this reason, we subject every whirlpool tub to extensive tests in terms of operation, feel, material quality and design. While all properties are put through their paces during the stress test with water, the long-term test is primarily used to check the pipes, hoses, jets and connections for leaks. However, the unique quality assurance of our Whirlcare® whirlpools takes place in our in-house climate chamber. This enables us to test the whirlpools under different climatic conditions and analyze their effects on energy consumption and noise emissions. Each model is stressed and tested in the climate chamber for at least 8-10 weeks to ensure that it meets the highest quality standards. As one of the few manufacturers in the world with the most modern climate chamber, we can assure you that our hot tubs perform optimally even under extreme climatic conditions. We test them in heat, cold, high humidity and many other challenging environments to ensure they work reliably and efficiently at all times. With Whirlcare® you can rely on a long-term investment. Our hot tubs undergo rigorous testing to ensure they meet the highest standards and have a long service life. You can rely on first-class quality and optimum performance.



WHIRLCARE

# ADDED VALUE HOT TUB

## Increase the value of the property

Whirlcare® Whirlpools & Swim-Spas

A Whirlcare® hot tub is more than just a luxurious extra - it's a statement of longevity and timeless design. Each of our whirlpools has been carefully designed to meet the highest standards while integrating harmoniously into your home. Thanks to the high quality of our products and the use of premium materials, you can be sure that your hot tub will give you years of pleasure. Our hot tubs are designed to withstand the rigors of daily use and retain their beauty over time. But it's not just the quality and durability that make a Whirlcare hot tub a valuable investment. Studies by bsw-solar (German Solar Industry Association), Immoscout 24 and other renowned institutions have confirmed that a high-quality hot tub increases the value of a property by up to €45,000 on average when sold. This impressive increase in value results from the combination of quality, sustainability and the timeless design of our hot tubs. Potential buyers recognize the added value and exclusive atmosphere that a Whirlcare® hot tub brings. It becomes a highlight that sets your property apart from others and inspires prospective buyers. Give your property the wow effect and increase its value with a Whirlcare® whirlpool. Rely on quality, sustainability and modern design and benefit from an investment that not only pays off in terms of well-being, but also financially.

## No building permit!

**No bureaucratic hurdles at all**

No planning permission is required to set up a whirlpool (portable spa) in Germany or most other European countries! Enjoy pure relaxation and wellness without time-consuming approval procedures. Setting up your whirlpool is very simple. You can place it on any level and stable surface, be it your patio, your garden or another area of your property. The only requirement is a power connection so that you can fully enjoy the powerful functions of your whirlpool. Filling the hot tub is also straightforward. All you need is a normal garden hose to fill the water. No annoying lugging of buckets or complicated installations.



# Living sustainability

Committed to the future

## RESPONSIBILITY

Out of responsibility for our environment, we attach great importance to resource-conserving, sustainable production and durable materials that are free from harmful substances and recyclable. Anyone who buys a Whirlcare® whirlpool tub today will not have to dispose of it as hazardous waste in 20 years' time. Our whirlpools are not reinforced with environmentally harmful glass fiber, as is often the case, but with a multi-component reaction system based on polyurethane. The environmentally friendly and recyclable PU material does not contain any plasticizers or solvents. Most manufacturers use impregnated wood or WPC (wood-polymer materials) for the tub frame. The tub frame of a Whirlcare® pool, on the other hand, is made of highly stable, coated steel. This increases the service life and can still be recycled after tens of years. The protective panel of our whirlpools is also completely recyclable and is made of a very high-quality and durable material that is free from formaldehyde or other toxic substances. Our protective panel is of a much higher quality than conventional wood or plastic cladding, which is in need of maintenance and quickly becomes unsightly due to external weathering. The exterior cladding is characterized by its durability and light-fastness, is pliability and looks almost as good as the day it was delivered, even after ten years.

### The Whirlcare® sustainability strategy



#### Power supply via photovoltaics

Thanks to the additional photovoltaic system with an output of 750 kWp, we generate more than the electricity required for the Produktion. What's more, we even produce surplus energy.

#### Rainwater utilization

Thanks to the rainwater collection and treatment system, we save more than one million liters of fresh water every year and thus cover 100% of our own water requirements.

#### Reduction in energy requirements

Intelligent technologies for communication and information technology, as well as energy-efficient, driverless transport systems and the use of robots not only ensure the clean quality of our products, but also reduce energy requirements at the source of whirlpool and swim spa production.

#### Building intelligence indicator

By building the administration and the halls to the low-energy standard (>KfW55) with natural gas heating in conjunction with heat pumps, the building intelligence indicator was significantly increased and more than 50% of emissions are saved in this area alone. Building automation is the most important component of our energy management.

#### LED lighting & KNX control

Thanks to our LED lighting with intelligent control and energy-efficient use of a lot of daylight in the production halls, we reduce our energy requirements by around 80% and thus save around 32 tons of CO2 per year

#### Recyclable materials

By predominantly using recyclable materials and energy-saving raw materials, we are significantly reducing our ecological footprint.



# The environmental factor

Whirlcare® already produces climate positive

## ENERGY SAFING ARTIST

For Whirlcare® Industries, sustainable management has been a process for years that starts with rethinking and has been implemented in Industry Standard 4.0 thanks to innovative technologies and processes throughout the entire supply, manufacturing and value chain. This starts with the selection of raw materials and extends to resource- and environmentally friendly production and processing, as well as the use of sustainable and recyclable materials. Negative effects on the environment are minimized during production, while at the same time conserving energy and natural resources and minimizing the environmental impact of waste from production and consumption. Whirlcare® Industries is the world's first "CO<sup>2</sup> climate-neutral company" in the manufacture of whirlpools and swim spas. The modern production in industry standard 4.0, with robots and driverless transport systems, as well as SAP-supported production processes, has placed great emphasis on sustainability in all areas right from the start. With the construction of the new production halls and the logistics center in the low-energy standard KfW 55 and the associated purchase of additional land, the company premises were expanded to over 62,000 square meters. The company's own solar power plant on the roofs provides the power supply and makes production almost energy self-sufficient. Intelligent building technology with KNX control, smart applications in conjunction with energy-saving technology reduce energy requirements in the long term. Rainwater from the roof and open spaces is almost completely collected and reused for production. The SAP-supported work processes in conjunction with robots and driverless transport systems in industry standard 4.0 ensure a pleasant working environment for the employees. Not only is the production process climate-neutral, but the materials used to manufacture the whirlpools and swim spas are also sustainable. Great importance is attached to energy saving and recyclable materials. The life cycle assessment of the materials used in whirlpool and swim spa production takes into account DIN ISO 14040 and 14043, among other things. Whirlcare® attaches great importance to ISO 14041 for all materials used, which means a recycling approach in the sense of a closed cycle for reuse.

## Achieving goals together

Die Whirlcare® Sustainability strategy

As a guideline for our sustainability strategy, we follow the Sustainable Development Goals (SDGs) adopted by the United Nations in September 2015. These are primarily aimed at states, governments and organizations, but the economy and its large companies will play a very important role with their ideas on innovation, investment and shaping the future. To align the Whirlcare® sustainability strategy, we have oriented ourselves to the SDGs and focused on the goals that we can significantly influence with our production, employee orientation and supply chains. The biggest role is played by the initiative of our own environmentally friendly waste cycle, the inclusion and integration of foreign employees and the maintenance and optimization of the Whirlcare® value chains.

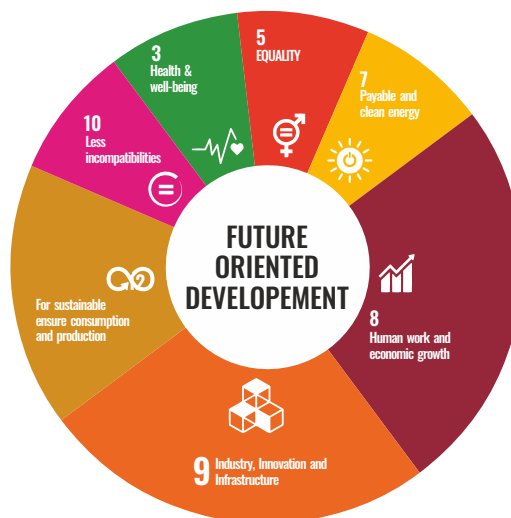



# ENERGY IS LIFE CYCLE

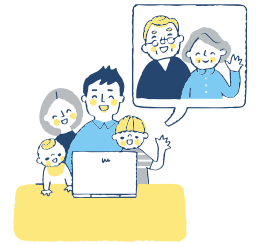

The hot tubs of the future  
need to understand life today

# The energy factor

Tested energy efficiency via in-house climate chamber

## ABSOLUTE TRANSPARENCY

When you get into your hot tub, you want to relax and not think about the electricity costs. The fact is that heating the water requires the most energy. This is why the type of insulation and the so-called U-value (thermal conductivity value) are of particular importance. PU foam or silver foil-coated polystyrene is often used to insulate whirlpool tubs - cheap to produce, but much more expensive in the long term from an ecological and economic point of view. For this reason, we use the chemically and biologically neutral high-performance insulation ISOGREEN - free from CFCs, HCFCs and HFCs and, of course, fully recyclable. Iso Green stands for a modern, environmentally conscious lifestyle. The graphite particles it contains reflect the heat emitted by the pumps and whirlpool tub, which is why no silver-reflecting foil is required. Our innovative ISOGREEN insulation achieves a low-energy standard with a U-value of 0.32. To achieve the same level of insulation efficiency, brickwork with a thickness of 55 cm would be required! Whirlpools with poorer insulation are usually slightly cheaper to buy. However, the price that has to be paid for this is often higher energy costs in the long term. Based on an average hot tub service life of 20 years, the difference between paying 30 or 150 euros a month for electricity adds up to a whopping 28,800 euros!

Whirlcare® is one of the few manufacturers in the world with its own climate chamber in which whirlpools and swim spas are tested and optimized for energy efficiency. The climate values from different regions provide us with reliable data on how much electricity your whirlpool actually needs. Whether your pool is located in Stuttgart, Moscow or Barcelona: From now on, energy costs are no longer a secret. As the main components of a whirlpool or swim spa are hidden behind the cladding, the appearance alone says nothing about the quality. It is therefore usually very difficult for the end customer to tell the difference between an inferior and a high-quality hot tub. This is now set to change: With its own professional climate chamber, Whirlcare® Industries is revolutionizing the global market for spas and setting new standards. 15 meters long, four meters wide and three meters high: these are the impressive dimensions of the climate chamber that Whirlcare® uses to test and develop its new, energy-efficient whirlpools and swim spas. It forms the basis for testing and checking pools with a length of up to twelve meters in long-term operation under simulated conditions that are as close to reality as possible. For example, temperature and humidity profiles, UV radiation and vibrations, noise and sound, but above all the actual energy consumption are simulated depending on the climatic conditions.

Whether a hot tub is installed and operated in the south of Spain or in Stuttgart makes a big difference. For this reason, the different climatic conditions of individual countries or regions can be realistically simulated in the factory's own climate chamber. (e.g. temperature and humidity) This allows the actual energy consumption to be determined and verified for an average period of use and water temperature under the respective climatic conditions. At the same time, long-term tests and comparisons can be carried out for the materials, components and insulation used, and quality and durability can be significantly improved.

This transparency will contribute to the introduction of energy labels or energy classes from D to A+++ for whirlpools and swim spas in the future - similar to refrigerators - and the average energy consumption per year can be specified. A sound measurement also provides a lot of information about the noise development in decibels during the circulation of the water or during operation. This is particularly important if the appliance is installed in the immediate vicinity of a neighbor or bedroom. The measuring instruments used here record and log the incoming data on water and outside temperature, humidity, sound level and energy consumption. All measurement data, including video surveillance, is archived reliably and seamlessly, and faults and limit violations are reported via switching output, text message or email. The professional software displays all information clearly in visualization charts and diagrams and enables quick access to current and previous data.

The introduction of an energy label, which is a particular concern of ours, will improve the quality of products and bring more transparency to the market. At Whirlcare®, we are convinced that an energy efficiency label for whirlpools and swim spas will become established in the coming years. This will enable the end consumer to quickly identify poor heat and sound insulation, an inferior cover or circulation pumps that are too loud based on the information provided, making it easier for them to make a decision. However, it will be some time before the European legal framework is in place. Initial marketing attempts to establish an energy comparison with competitors have unfortunately so far led to warnings from competitors under advertising law, as they obviously cannot keep up and consume considerably more energy!

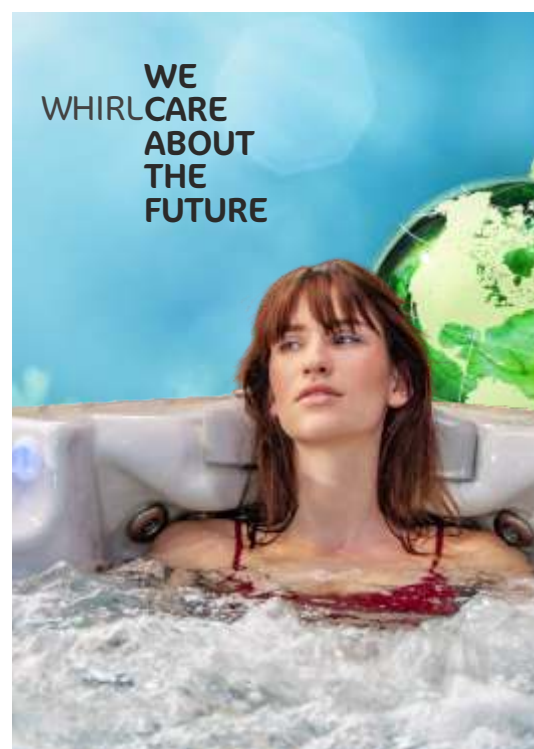

# Awarded brand & products

That's something to be proud of

## WALL OF FAME

We are proud that Whirlcare has received numerous prestigious awards and accolades for our excellence in recent years. These recognitions confirm our outstanding quality, innovative design and technological advances. Among the many awards Whirlcare has received are the German Innovations Award, which we have won several times. This prestigious award recognizes our innovative strength and commitment to advanced technologies. The PlusX Award has also honored us several times, recognizing various aspects such as design, ease of use, technology and quality. These awards are a testament to the fact that Whirlcare not only offers aesthetically pleasing hot tubs, but also meets the highest standards in terms of technology and user experience. The EUSA Award, which we were also proud to receive, underlines our leading position in the industry and recognizes our continuous efforts to develop the best products for our customers. These awards are not only a confirmation for us, but also a motivation to always offer our customers the best possible products and the ultimate wellness experience. We continue to focus on innovation, quality and customer satisfaction to consolidate our position as a leading hot tub supplier. See for yourself why Whirlcare has won so many awards. Immerse yourself in a world of luxury and relaxation with our award-winning hot tubs. Whirlcare - your partner for exceptional quality and incomparable wellness moments.



„We help successful people to reduce stress,  
relieve tension and increase their  
performance!“

(Guideline for the Whirlcare® XE hot tub series)

# List of sources

We didn't just make it up

There's a lot of sense in that

1) European Health Center for Naturopathic Methods - Sebastian Kneipp Institute GmbH: "Naturopathic Methods - Safe and Effective Methods of Naturopathic Medicine", p. 16 ff: "Healthy through water".

2) Lowering Blood Pressure Through Hydrotherapy: A randomized, controlled trial in mild to moderate hypertension. E.-M. Jacob, E. Volger. Bad Wörishofen Clinic of the German Pension Insurance Swabia.

3) Genuario, Susan E.; Vegso, Joseph J.: "The use of a swimming pool in the rehabilitation and reconditioning of athlete injuries". Contemporary orthopedics, 20/1990.

4) Impulse - the science magazine of the German Sport University Cologne (special edition): "Movement alternative Aqua-Cycling?!", p. 6: "Advantages of physical movement in water".

5) "The bath in the whirlpool improves the microcirculation of the skin and subcutaneous tissue and leads to tissue loosening and blood circulation. It helps with low blood pressure, muscle tension, mental-physical exhaustion and inadequate defenses. - www.klinikforte.de -, clinic portal for health trips, rehabilitation clinics and health clinics.

6) In 1995, a study published in the British Journal of Rheumatology found that whirlpool therapy had both short- and long-term benefits for people with lower back pain. A later study published in the Journal of Rheumatology by a group of researchers in France showed that after three weeks of consistent whirlpool therapy, tests showed further improvement. The state of health was measured in terms of pain, its duration and intensity as well as the flexibility of the limbs. The comparison was made between a group with whirlpool treatment and a group with purely drug treatment. After six months there were further significant improvements in the whirlpool therapy group. In addition, the use of analgesics and anti-inflammatory drugs was reduced. This research information was published in the March / April 1996 issue of Arthritis Today. Italian researchers noted in the Journal of Investigative Medicine in 1998 that the amount of anti-inflammatory and pain relievers for arthritis pain and joint destruction could be reduced after three weeks of whirlpool therapy.

7) Hydrotherapy in hot tubs can also affect diabetes, according to a study in the USA. Dr. Philip L. Hooper from McKee Medical in Loveland, Colorado, put eight diabetics between the ages of 43 and 68 in a whirlpool for half an hour six days a week. The water was 37 ° C - 41 ° C. After three weeks, the mean fasting blood sugar had decreased significantly, the patients also lost an average of 1.7 kg and reported that they could sleep better and generally felt more comfortable as the bath treatment progressed. - Philip L. Hooper, M.D., published in the New England Journal of Medicine, September 1999: "Hot-Tub Therapy for Type 2 Diabetes Mellitus".

8) According to the Atlanta-based nonprofit Arthritis Foundation, "Using a hot tub regularly can help keep your joints moving. It restores strength and flexibility, respectively, maintains them and also protects (...) joints from further damage. Whirlpools perfectly meet this need. The warmth, massage and buoyancy are necessary for the well being of the arthritis patient. The buoyancy of the water supports and reduces the pressure on the joints and promotes mobility."

9) Effect of hydrotherapy in knee and hip osteoarthritis: M. Schencking, S. Wilm and M. Redaelli, January 2013.

10) Catharina Sadoghiani et al: "Effectiveness of overheating baths in depression - results of a randomized, controlled study", awarded the Holzschuh Prize for Complementary Medicine in Baden-Baden. Dr. Catharina Sadoghiani has now been able to show for the first time that 20 to 30-minute overheating baths at 40 ° C cause a clinically significant improvement in depressive symptoms and sleep quality after just 4 applications. The study was carried out in a heated whirlpool in a thermal bath.

11) Water buoyancy reduces physical strain: The weightlessness of the body in a hot tub can help to relieve stress and physical strain. A study by E. J. Sung and Y. Tochiwara analyzed how soaking in warm water improved sleep. The US National Swimming Pool Foundation (NSPF) suggests that this sleep improvement could be a result of the buoyancy of the water. The water supports about 90 percent of the normal body weight, relieves joints and muscles and makes you weightless.

12) During his research, Dr. Bruce Becker, a physician and research professor at Washington State University, found that the sympathetic nervous system, which becomes more active when you are stressed, and the parasympathetic nervous system, which helps the body to calm down, rebalance when you lie in warm water. According to this, the nervous system reacts to warm water in the same way as it reacts to meditation or other relaxed states. During his studies, Becker found that the stress level had decreased in all test subjects who had immersed their bodies in warm water.

13) In addition to relaxation through the buoyancy of water and immersion in warm water, therapeutic massages from whirlpools help to relax body and mind. According to the University of Maryland / Medical Center, massage reduces stress hormones and increases the release of endorphins, which are natural mood enhancers and pain relievers. The American Cancer Society also points out that massage jets provide relaxation and stress relief.

14) "With water against headaches and migraines": Peter W. Gründling, Professor of Naturopathy and Complementary Medicine at the Fresenius University in Idstein.

15) "Pool Therapy": Loudon, Janice Kaye, published in the magazine "Athletic Training", 22/1987/16) "Regeneration in the whirlpool": Interview with Dr. Willi Heepe, published on www.runnersworld.de / whirlren

17) Diday-Nolle, Breier, Slatosch Wintsch, Reiter Eigenheer: "Hand Rehabilitation for Occupational Therapists and Physiotherapists", Volume 1, 3rd edition: 4.15. Application forms of thermal hydrotherapy.

18) A study carried out at the Naturopathic Competence Center of Jena University Hospital in 2006 shows that the professional treatment of the corresponding foot reflex zones can alleviate pain and functional impairment in moderate knee osteoarthritis ("Effectiveness of foot reflex zone therapy in gonarthrosis proven"). Two further studies use color-coded double sonography to show an increased blood flow to organs in the intestine and in the right kidney due to foot reflexology.

19) "Effects of underwater massage on the responsiveness of the motoric neural system": K. Gieremek, published in "Biology of Sport, 7/19990.

20) "Warm underwater water-jet massage improves recovery from intense physical exercise": Viitasalo, J.T.; Niemelae, K.; Kaappola, R.; Korjus, T.; Levola, M.; Mononen, H.V.; Rusko, H.K.; Takala, T.E.S., published in the European Journal of Applied Physiology, 71/1995.

21) "The seven pillars of aquatraining and their health-promoting effects": Andreas Hahn, published in "Praxis Physiotherapie".

22) Pablo Tomas-Carus, professor in the field of health and sport at the University of Évora / Portugal, examined the effects of training in warm water in 34 patients with fibromyalgia syndrome. Compared to the control group, there were significant improvements in muscle strength and strength, quality of life and pain. ("Improvements of muscle strength predicted benefits in HRQL and postural balance in women with fibromyalgia: an 8-month randomized controlled trial").

23) Evelyn Deutsch, Bärbl Buchmayr, Marlene Eberle: "Aroma Care Manual", p. 61ff: "Science and Practice".

24) "Aquatraining - health-oriented exercise programs": Jeanette Hahn, Andreas Hahn, Meyer & Meyer Verlag, Aachen, p. 36 ff.

25) "Aqua training: reduce calories in a way that is gentle on the joints": dpa report in the "Augsburger Allgemeine", published on www.augsburger-allgemeine.de

26) "Sport in Prevention / Health Promotion": A manual for offers in the "Aquatic Movement Area", published by the Landessportbund Nordrhein-Westfalen e.V. in cooperation with the Swimming Association of North Rhine-Westphalia e.V.

27) German Arthrosis Aid e.V. (www.arthrose.de)

28) "A comparison of Kneipp hydrotherapy with conventional physiotherapy in the treatment of osteoarthritis: a pilot trial": M. Schencking, S. Wilm and M. Redaelli, January 2013





WHIRLCARE® XE

WHIRLPOOLS & SWIM-SPAS  
MADE IN GERMANY

SMART  
SUSTAINABLE  
ENERGY EFFICIENT  
HEALTH-PROMOTING

WE  
WHIRLCARE  
ABOUT THE  
WORLD AND  
THE  
FUTURE





It's up to you what you make of your home! Put your garden in "POOL" position. We think it's time to take a look at one. Simply call now and make an appointment. We'll tell you the name of your nearest specialist dealer and you can get comprehensive personal advice.

EUROPE  
 GERMANY  
 BADEN-WÜRTTEMBERG  
 DISTRICT of ROTTWEIL  
 Between Stuttgart und Lake Constance)

Whirlcare® Industries GmbH  
 Römerstrasse 160-164  
 D-78652 Deißlingen-Laufen  
 Baden-Württemberg / GERMANY

+49 (0) 74 20 / 92 003 -0  
 info@whirlcare.com  
 www.whirlcare.com



## Impressum

Whirlcare Industries GmbH  
 Römerstrasse 168  
 D-78652 Deißlingen-Laufen | GERMANY  
 Tel. +49 (0) 74 20 / 92 003 -0  
 Email: info@whirlcare.com  
 Internet: www.whirlcare.com

Geschäftsführerin / CEO: Edelgard Knoll  
 Handelsregister / Commercial register: AG Stuttgart, HRB 765837  
 USt.-IdNr. / VAT Number: De319460268  
 EAR registration number: WEEE-Reg.-Nr.: DE 40367242

Chefredaktion und Art-Direction:  
 Otmar Knoll, Director and Owner,  
 Marcel Riedlinger, Creative Director

All content, text and graphics are protected by copyright. They may not be copied, modified, reproduced or published in whole or in part without prior written permission. © Whirlcare Industries GmbH 2023/2024. Some of the images were acquired from the Internet platforms iStock® (istock.com), Freepik (freepik.com) and Envato® (envato.com) and inserted with a license. All other images in this catalog are the property of Whirlcare Industries GmbH and were taken by in-house photographers. We accept no liability for printing errors and mistakes. Subject to change without notice. Legal action excluded. The illustrations of the products or their individual components may differ from the original. Subject to technical changes.

© Whirlcare Industries GmbH 2023/2024

Dieser Katalog wurde Ihnen überreicht durch / This catalogue was given to you by:



Die Whirlcare® Nachhaltigkeitsstrategie orientiert sich an den  
The Whirlcare® sustainability strategy is based on the

**SUSTAINABLE  
DEVELOPMENT GOALS**

Whirlcare Industries GmbH  
Römerstrasse 160  
D-78652 Deisslingen-Lauffen  
GERMANY

Tel.: +49 (0) 74 20 / 92 003 -0  
Email: [info@whirlcare.com](mailto:info@whirlcare.com)

[www.whirlcare.com](http://www.whirlcare.com)